

Operating Manual

Translation of the Original Instructions



FocusMonitor FM+ LaserDiagnosticsSoftware 2.98

Contents

1	BASIC SAFETY INSTRUCTIONS	7
2	SYMBOL EXPLANATIONS	9
2.1	About this operating manual	11
3	CONDITIONS AT THE INSTALLATION SITE	11
4	INTRODUCTION	12
4.1	Laser beam measurement	12
4.2	Brief overview installation, measuring operation, evaluation.....	14
5	INSTALLATION	15
5.1	Preparation.....	15
5.2	Installation position.....	16
5.3	Alignment	17
5.4	Mounting	18
6	ELECTRICAL CONNECTIONS	20
6.1	Connection FM+ with the standard power supply and the PC (example)	22
6.2	Operation of two measuring devices	23
7	INERT GAS CONNECTION	24
8	STATUS DISPLAY	24
9	SOFTWARE	25
9.1	System requirements	25
9.2	Installing the software	25
9.3	Starting the software	26
9.3.1	Graphical user interface	26
9.3.2	Menu overview	30
9.4	Establishing an Ethernet Connection.....	32
9.4.1	Establishing a connection to PC	33
9.4.2	Changing the IP address	33
10	SOFTWARE FUNCTIONS IN DETAIL	35
10.1	Settings	35
10.1.1	Sensor parameter	35
10.1.2	Measuring Environment (menu Measuring>>Environment).....	39
10.1.3	Beam find (Menu Measurement>>BeamFind settings).....	40
10.1.4	Single measurement (menu Measurement>>Single measurement).....	41
10.1.5	Caustic measurement.....	44
10.2	Presentation and documentation of the measuring results.....	48
10.2.1	False colors.....	49
10.2.2	False colors (filtered)	50
10.2.3	Isometry	50
10.2.4	Caustic display (2D-display)	51
10.2.5	Isometry 3D	55
10.2.6	Review 86 % or 2 nd Moment.....	56
10.2.7	Symmetry Check	57
10.2.8	Fixed Contour Lines.....	58
10.2.9	Variable Contour Lines.....	59
10.2.10	Graphical Review	60
10.2.11	Color Tables	60
10.2.12	Position	61
10.2.13	Evaluation **OPTION**	62

10.3	File	63
10.3.1	New	63
10.3.2	Open	63
10.3.3	Save	63
10.3.4	Save As	63
10.3.5	Export	63
10.3.6	Load measurement preferences	63
10.3.7	Save measurement preferences	63
10.3.8	Protocol	64
10.3.9	Print	64
10.3.10	Print preview	64
10.3.11	Recently opened files	64
10.3.12	Exit	64
10.4	Edit	64
10.4.1	Copy	64
10.4.2	Clear plane	64
10.4.3	Clear all planes	64
10.5	Communication	65
10.5.1	Free Communication	65
10.5.2	Scan device list	65
10.6	Script	66
10.6.1	Editor	66
10.6.2	List	66
10.6.3	Python	66
11	MEASURING	67
11.1	Special safety instructions	67
11.2	Requirements	69
11.3	Possible Types of Measurement	69
11.3.1	Single Measurement	69
11.3.2	Caustic measurement	69
11.4	Brief Instruction for a first Single Measurement	70
11.5	Measurement with a DFY-PS+/DFIG-PS+ Detector	74
12	DISCUSSION OF THE MEASURING RESULTS AND ERROR ANALYSIS	76
13	TROUBLESHOOTING	78
14	VARIETY OF DETECTORS AND MEASUREMENT TIPS	79
14.1	Limit Values for the Measurement Procedure with HP-CO ₂ Measurement Tips	81
14.2	Limit Values for the Measurement Procedure with FK High Div-Measurement Tips	82
14.3	Exchanging or Twisting the Measurement Tip	83
14.4	Changing the Detector	85
15	MAINTENANCE	87
16	TRANSPORT	87
17	MEASURES FOR THE PRODUCT DISPOSAL	87
18	DECLARATION OF CONFORMITY	88
19	TECHNICAL DATA	89
20	DIMENSIONS	90
20.1	Position of the Pinhole Tip at the FocusMonitor (in reference to the device coordinates)	92

21	APPENDIX	93
21.1	System control	93
21.2	Description of the MDF file format.....	93
22	BASIS OF BEAM DIAGNOSIS	95
22.1	Laser beam parameter	95
22.1.1	Rotationally symmetric beams.....	96
22.1.2	Non rotationally symmetric beams:.....	97
22.2	Calculation of beam data	98
22.2.1	Determination of the zero level	98
22.2.2	Determination of the beam position	99
22.2.3	Radius determination with the 2 nd moment method of the power density distribution	99
22.2.4	Radius determination with the method of the 86 % power inclusion	100
22.2.5	Further radius definitions **OPTION**	101

PRIMES - The Company

PRIMES is a manufacturer of measuring devices used for the characterization of laser beams. These devices are used for the diagnostics of high power lasers that range from high power CO₂-lasers and solid-state to fiber lasers and diode lasers. A great variety of measuring devices for the determination of the following parameters is available:

- The laser power
- The beam dimensions and the beam position of an unfocussed beam
- The beam dimensions and the beam position of a focussed beam
- beam quality factor M^2
- polarization of the laser beam

Both the development and the production of the measuring devices are effected by PRIMES. This is how we ensure an optimal quality, excellent service and a short reaction time which is the basis to meet our customers' requirements fast and reliably.



1 Basic safety instructions

Intended use

The FocusMonitor (FM+) is exclusively intended for measurements carried out in or near the optical path of high power lasers. Other forms of usage are improper. To ensure a safe operation, the devices must only be operated according to the terms stipulated by the manufacturer.

Improper usage of the devices is strictly prohibited and could lead to health endangering or even deadly injuries. When operating the devices it must be ensured that there are no potential hazards to human health.

The device themselves do not emit any laser radiation. During the measurement, however, the laser beam is guided through the device which causes scattered radiation (**laser class 4**). That is why the applying safety regulations are to be observed and necessary protective measures need to be taken.

Observing applicable safety regulations

Personal protection is required when humans are present in a dangerous zone with uncovered visible or invisible laser radiation or particularly uncovered laser beam systems, beam guiding systems or process regions. This holds true for any application of this equipment. During measurement procedures there is always an unavoidable risk of laser radiation through direct or reflected emissions. The applicable safety regulations are stipulated in ISO/CEN/TR standards as well as in the IEC-60825-1 regulation, in ANSI Z 136 "Laser Safety Standards" and ANSI Z 136.1 "Safe Use of Lasers", published by the American National Standards Institute, and additional publications, such as the "Laser Safety Basics", the "LIA Laser Safety Guide", the "Guide for the Selection of Laser Eye Protection" and the "Laser Safety Bulletin", published by the Laser Institute of America, as well as the "Guide of Control of Laser Hazards" by ACGIH.

Taking necessary safety measures



DANGER

Danger of injuries due to scattered radiation.

On the basis of the measuring principle the laser beam is reflected at the measuring tip (laser class 4).

- ▶ **In operation, a safety distance of 1 meter to the FocusMonitor has to be kept even with safety goggles and safety clothing!**

If there are people present within the danger zone of visible or invisible laser radiation, for example near laser systems that are only partly covered, open beam guidance systems or laser processing areas, the following safety measures need to be taken:

- Please wear safety goggles (OD 6) adapted to the laser wave length that is in use.
- Please protect yourself from direct laser radiation, scattered radiation as well as from beams generated from laser radiation (for example by using appropriate shielding walls or by weakening the radiation to a harmless level).
- Please use beam guidance – or beam absorber elements which do not emit any hazardous particles as soon as they get in contact with laser radiation and which resist the beam sufficiently.
- Please install safety switches and / or emergency safety mechanisms which enable an immediate closure of the laser shutter.
- Please ensure a stable mounting of the measuring device in order to prevent a relative motion of the device to the beam axis. This reduces the risk of scattered radiation and is also necessary to ensure an optimal performance for the measurement.

Employing qualified personnel

All users of the FocusMonitor must have been introduced to the handling of the measuring device and need to have basic knowledge about the work with high power lasers, beam guidance systems as well as focusing units.

Modifications

The FocusMonitor must not be modified, neither constructional nor safety-related, without our explicit permission. Modifications of any kind will result in the exclusion of our liability for resulting damages.

Liability disclaimer

The manufacturer and the distributor of the measuring devices do not claim liability for damages or injuries of any kind resulting from an improper use or handling of the devices or the associated software. Neither the manufacturer nor the distributor can be held liable by the buyer or the user for damages to people or material or financial losses due to a direct or indirect use of the measuring devices.

2 Symbol explanations

The following symbols and signal words indicate possible residual risks:



DANGER

means that death or serious physical injuries **will** occur if necessary safety precautions are not taken.



WARNING

means that death or serious physical injuries **can** occur if necessary safety precautions are not taken.



CAUTION

means that a slight physical injury **can** occur if necessary safety precautions are not taken.

NOTICE

means that property damages **can** occur if necessary safety precautions are not taken.

The device itself or the packing bears the following symbols to indicate requirements and possible dangers:



Warning of laser radiation



Warning of hand injuries



Read and observe the operating instructions and safety guidelines before the start-up!

Further symbols that are not security relevant:



Here you can find useful information and helpful tips.

CE With the CE designation, the manufacturer guarantees that its product meets the requirements of the relevant EC guidelines.

▶ Call for action

2.1 About this operating manual

This documentation describes the work with the FocusMonitor and the operation with the “LaserDiagnostics-Software” (in the following called “LDS”).

As far as the description of the software is concerned, the focus lies upon the configuration- and communication settings as well as the measuring operation.



This operating manual describes the software version v2.98.8, which is applicable at the time of printing. Due to the fact that the user software is continuously advanced, it may be possible that the attached installation CD bears a different version number. The correct functioning of the device, however, is ensured with the software.

Should you have any questions, please be so kind as to provide us with the software version installed on your computer. The software version, the creation date as well as the Windows® version our LaserDiagnosticsSoftware was programmed for can be found in the following menu item: **Help>>About LaserDiagnosticsSoftware.**

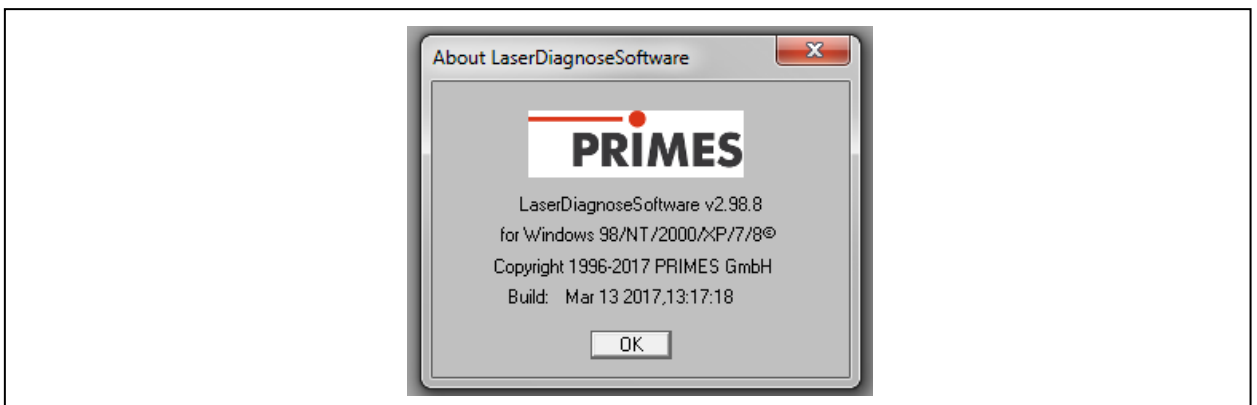

Fig. 2.1: Information regarding the latest software version

3 Conditions at the installation site

- The measuring devices must not be operated in a condensing atmosphere.
- The ambient air must be free of organic trace gases.
- Please protect the devices from water and dust.
- Operate the measuring devices in closed rooms only.



CAUTION

Fire and explosion hazards due to laser radiation.

Scattered radiation is developed during the measurement.



Do not store flammable materials or highly flammable substances in the area of measurement.

4 Introduction

4.1 Laser beam measurement

The production with laser beams can be monitored more effectively by means of the control of laser beam parameters. The laser beam is basically characterized by:

- the beam power
- the beam dimensions and the beam position of the unfocussed beam
- the beam dimensions and the beam position in the focus
- the polarization of the laser beam.

The basic laser beam parameter have a great influence on the results of the laser material processing. In order to achieve a reproducible process quality it is necessary to detect all changes with regard to the beam parameters. Changes can be caused not only by:

laser internal reasons, for example

- the aging or pollution of optical components or
- the misalignment of the resonator

but also by:

effects in the beam guidance system or the focussing unit, for example

- the pollution or the misalignment of mirrors or lenses
- traces of organic gases in the air – thermal blooming

The processing result for the production with lasers is generally dependant on the beam power as well as the power density in the focussing range. Moreover, the position of the focussing point in relation to the processing zone must be known. Variations to these nominal sizes often lead to a reduced processing speed or processing quality.

Periodic measurements of the laser beam parameters enable a reliable control of the “tool” laser beam. This is a basic requirement for a reproducible production with the laser beam and therefore for the quality assurance.

PRIMES has developed measuring systems that are able to carry out measurements even in an industrial environment.

Laser beam radius, -position and power density distribution in the focus as well as in the unfocussed beam have a strong influence on the result of the laser material processing. In order to achieve a reproduce a reproducible processing quality it is necessary to detect all variations of the beam parameters and to register them.

The FocusMonitor (Fig. 4.1) is intended for the analysis of **focussed** laser beams. The device measures the spatial power density distribution in the focus range of the processing optics. On the basis of this, the system calculates the beam radius, the focus position in the space as well as the beam propagation ratio K or – respectively – the beam quality factor M^2 .



Fig. 4.1: FocusMonitor FM+

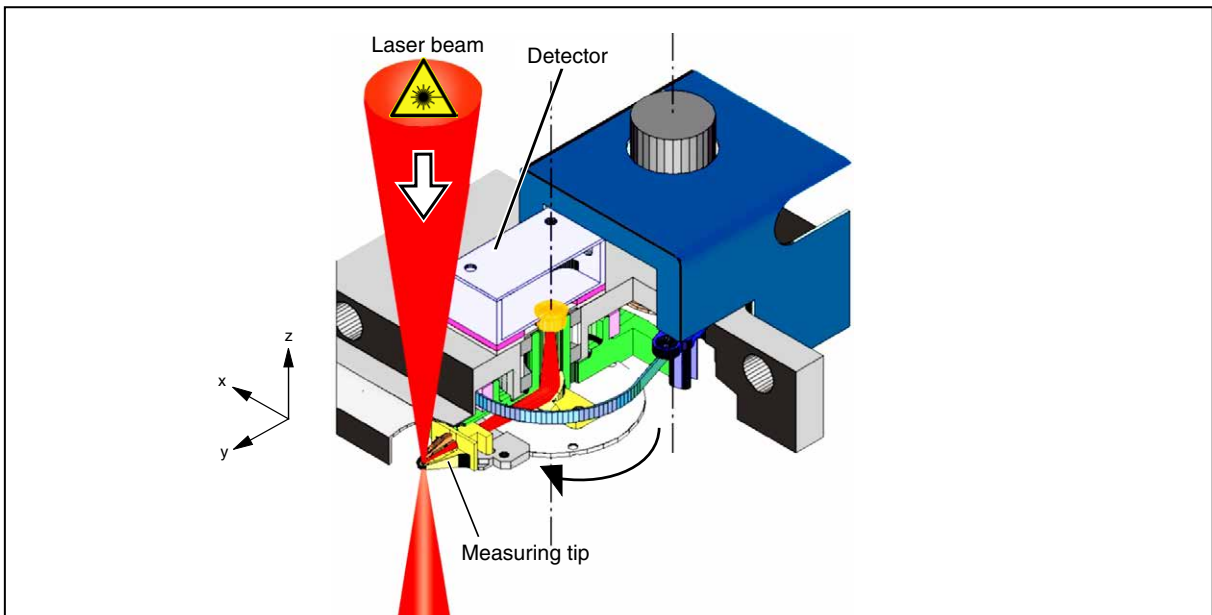

Fig. 4.2: Optomechanical assembly of the FocusMonitor FM+

In order to determine the power density distribution in the focus of a FocusMonitor, a rotating measuring tip is used which scans the cross-section of the laser by means of a linear scanning in y-direction. Here, the tiny aperture of the measuring tip (pinhole) decouples a small part of the beam. Mirrors then guide the measuring signal to a detector. The whole measuring head can be moved automatically via an integrated z-axis. Due to this, the propagation parameters can be determined completely by moving along the beam caustic.

Due to the employment of different detectors as well as different measuring tips the FocusMonitor can be adapted to the requirements of the beam diagnosis in a wider wavelength range as well as power density range. The application ranges of the systems reach from some MW/cm^2 up to a few W/cm^2 . Detailed descriptions regarding other detectors and also measuring tips can be found in chapter 14 on page 79.

4.2 Brief overview installation, measuring operation, evaluation

1. Taking necessary safety precautions

- minimizing scattered radiation and shielding residual radiation
- ensuring that the radiation behind the measuring zone is fully absorbed
- wearing safety goggles

2. Installation

- Alignment to the laser beam
- stable mounting
- Checking the beam path in the measuring range
- Connecting electronically.
- Installing / Starting the LaserDiagnosticsSoftware
- Checking the communication between the computer and the measuring devices (menu **Free communication**, button **Test**)

3. Measuring

- **Single measurement** (automatic or manual configuration): The position and the size of the measuring window can be adjusted relatively with regard to the maximum measuring range. The amplification can be adjusted separately.
- **Caustic measurement:** Serial measurement in case of which the z-position is gradually changed. The parameters are set automatically or manually. The beam quality factor M^2 (beam propagation ratio K) can be determined directly.

4. Presentation

- 3D-presentation (Isometry) of the spatial power density distribution
- Contour line presentation of the spatial power density distribution in false colors
- Freely selectable contour line cuts in x- and y-direction as well as after power densities
- Fixed contour line cuts in x- and y-direction for 86 %, 80 %, 60 %, 40 %, 20 % and 10 %
- Caustic display/3D
- Symmetry checks
- Remarks as well as measuring parameters can be integrated and stored
- The following parameters are displayed numerically: beam radius, x-beam radius, y-beam radius, angle, x-position, y-position, laser power density, date, time, laser power
- Graphical overview of different beam parameters
- Presentation of different measuring results (planes)

5. Documentation

- Storing the measured data in files and uploading the data again
- Storing the latest settings and uploading the data again
- Printing the current window content
- Copying the current window content to the clipboard
- Exporting measured numerical data: radius, position in a tab-separated text-data (after the measurement)
- Drawing up a log file of the calculated numerical values – concurrent to the measurement

5 Installation

5.1 Preparation

Before the mounting, please check the space available, especially the necessary space for the movement range of the FocusMonitor (see chapter 19 on page 89).

The measuring device must be assembled stably and must be affixed by means of screws (please see chapter 5.4 on page 18).

NOTICE

There is a danger of damage

Obstacles in the movement range of the FocusMonitor can lead to collisions and can damage the device.

- ▶ **Keep the movement range free of obstacles (cutting nozzle, pressure roll etc.). Please make sure that the measuring head moves automatically into its resting position after the power supply was turned off and on again or after a reset. Please also keep this range free.**

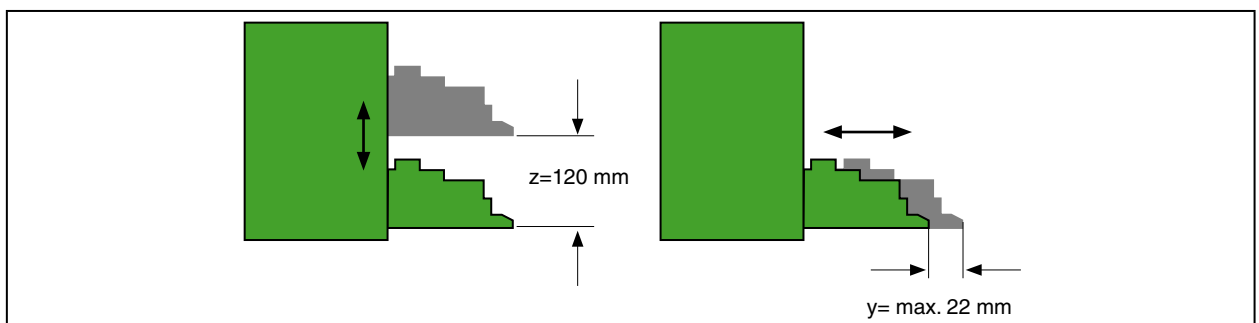

Fig. 5.1: Movement range of the measuring head



In the LaserDiagnosticSoftware you have the option to restrict the movement range of the FocusMonitor (see chapter 10.1.1 on page 35).

NOTICE

There is a danger of damage / a fire hazard

After passing the device, the laser beam has to be absorbed completely. Fire bricks or other partly-absorbing surfaces are not suitable!

- ▶ **Please use an adequate absorber, e.g. the PRIMES PowerMonitor.**

NOTICE

Danger of damage for the absorber

If the laser focus hits the absorber, it can be destroyed.

- ▶ **Please ensure an adequate distance between the FocusMonitor and the absorber (the maximum power density of the absorber must not be exceeded).**

5.2 Installation position

You can install the device in two different positions (see Fig. 5.2). In the intended standard position with a beam entrance from above (image A) or “upside down” with a beam entrance from underneath (image B). In case of difficult installation conditions, you have the possibility to turn the measuring tip 180° (see chapter „14.3 Exchanging or Twisting the Measurement Tip“ on page 83). Then you can also measure a beam entering from above in the “upside down” position, image C.

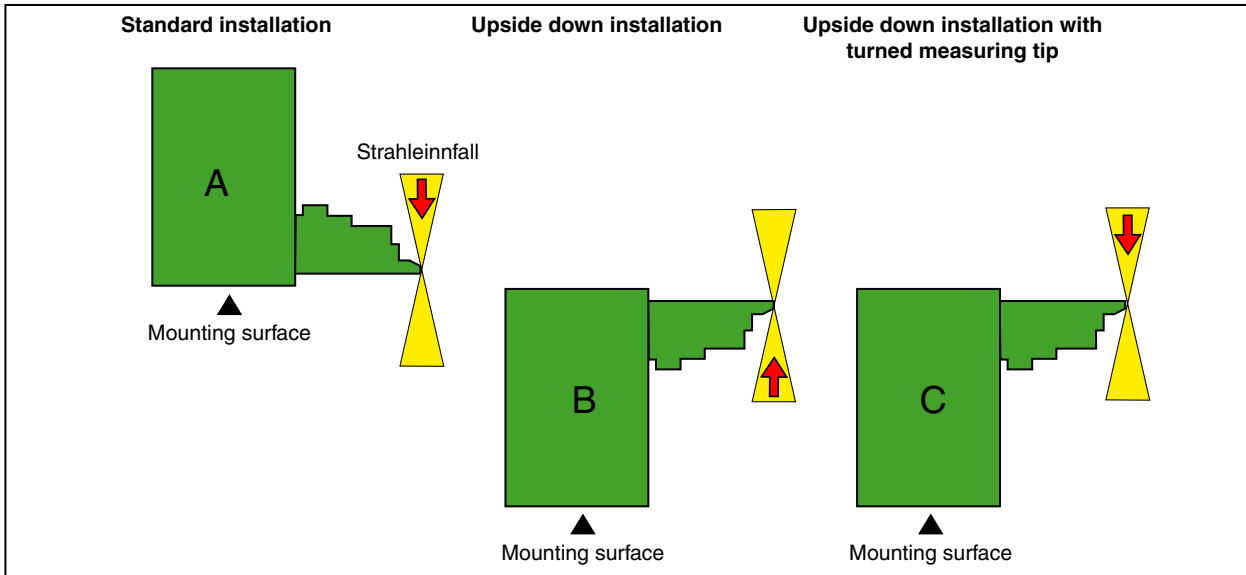

Fig. 5.2: Mounting options for the FocusMonitor

In order to prevent transport damages, the measuring tip is delivered dismounted. When built in, the curved part has to point towards the beam source (please see Fig. 5.3). Further information regarding the mounting of the measuring tip can be found in chapter 14.3 on page 83.

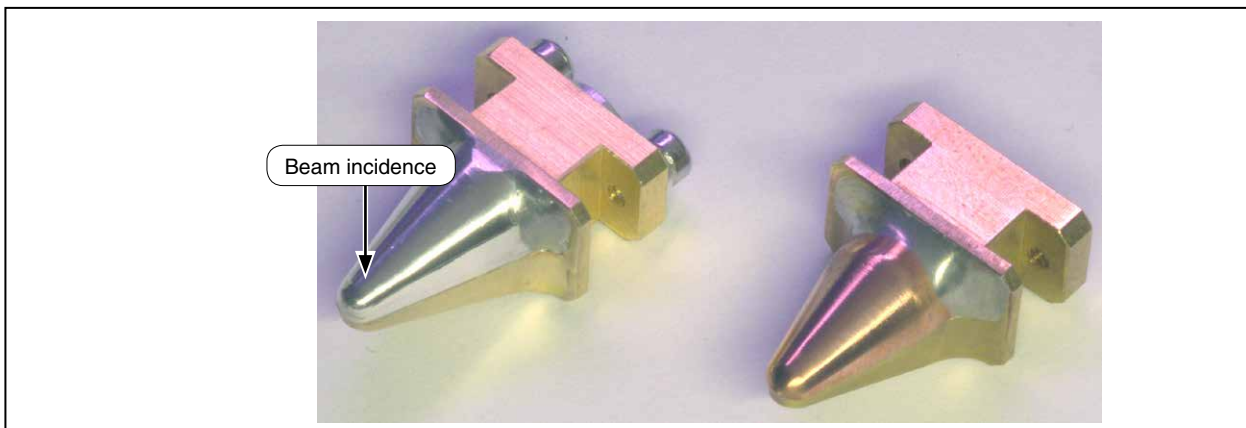

Fig. 5.3: Direction of the measuring tip when built in

5.3 Alignment

For the FocusMonitor a vertical beam entrance with regard to the x-y-plane needs to be ensured.



Caution

There is a danger of injuries due to rotating or moving parts

Due to the linear movement of the horizontal and vertical carriage and the rotating rotary disk, there is a risk of injury in the measuring operation.

- ▶ **Align the FocusMonitor only when the power supply is switched off and the measuring tip is no longer rotating.**

The vertical alignment (z-axis) is dependant on the focal length of the customer's focussing unit. The vertical stroke of the measuring device is 120 mm.

The beam focus should be in the middle of the movement range of the z-axis. This means about 60 mm with 120 mm stroke (see Fig. 5.4)

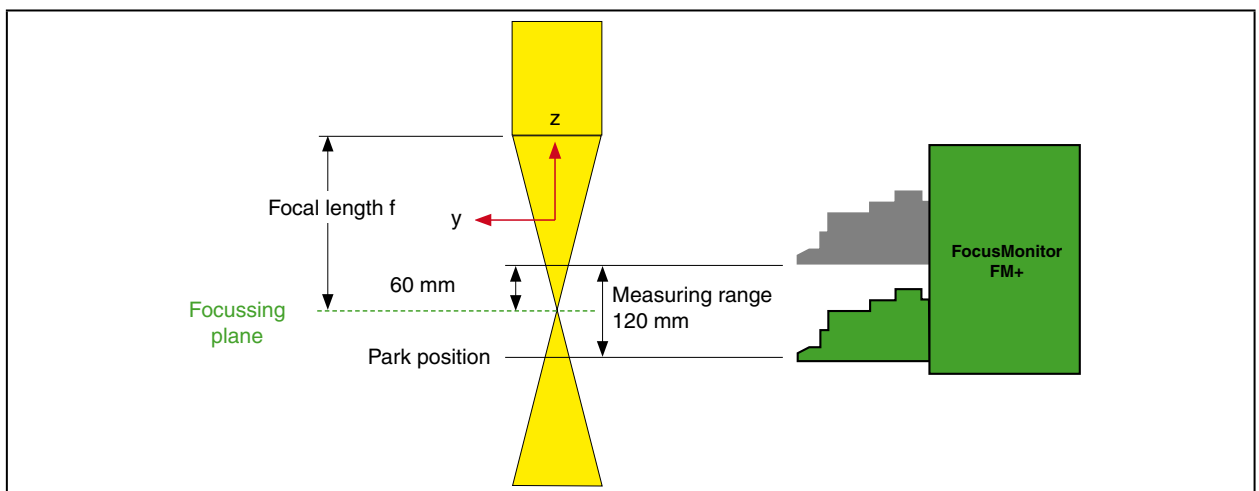

Fig. 5.4: Measuring range FM+

For a problem-free alignment (x-y-plane) towards the laser beam, an adjustment tool is delivered together with each device. Depending on the version of the device, the distances of adjustment differ and therefore also the tools.

The adjustment tools are put against the measuring head. Then it has to be ensured, that the pilot beam goes through the tiny hole in the tool when the device is aligned (see Fig. 5.5).

NOTICE

There is a danger of damage for the measuring tip

Should the laser beam hit the measuring tip in a resting position, it could be destroyed.

- ▶ **Move the measuring tip out of the measuring area after the mounting.**

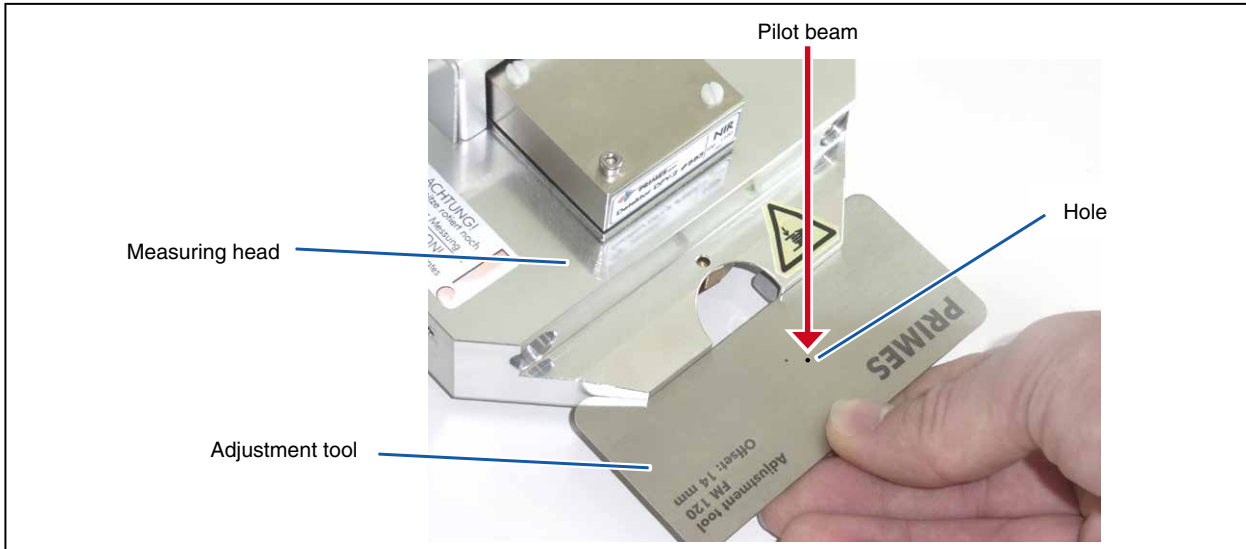

Fig. 5.5: Adjustment tool at the measuring head of the FocusMonitor FM+



After switching on the supply voltage, the FocusMonitor moves into the resting position (lowest z-position) after a period of 5-12 seconds.

5.4 Mounting



WARNING

There is a danger of injuries

If the appropriate position of the measuring device is changed, this could cause increased scattered radiation during the measurement.

- ▶ **When mounting the device, please ensure that it cannot be moved, neither due to an unintended push or a pull on the cables and hoses.**

In the mounting surface of the housing there are six through holes $\varnothing 6.6$ mm and two fit drills $\varnothing 6^{G7}$ mm intended for the customer's mounting. Please use at least four screws M6 to fasten the device. The total length of the screws depends on the dimensions of the customer's mounting. The dimensioned order of the fixing holes can be found in chapter 20 on page 90.

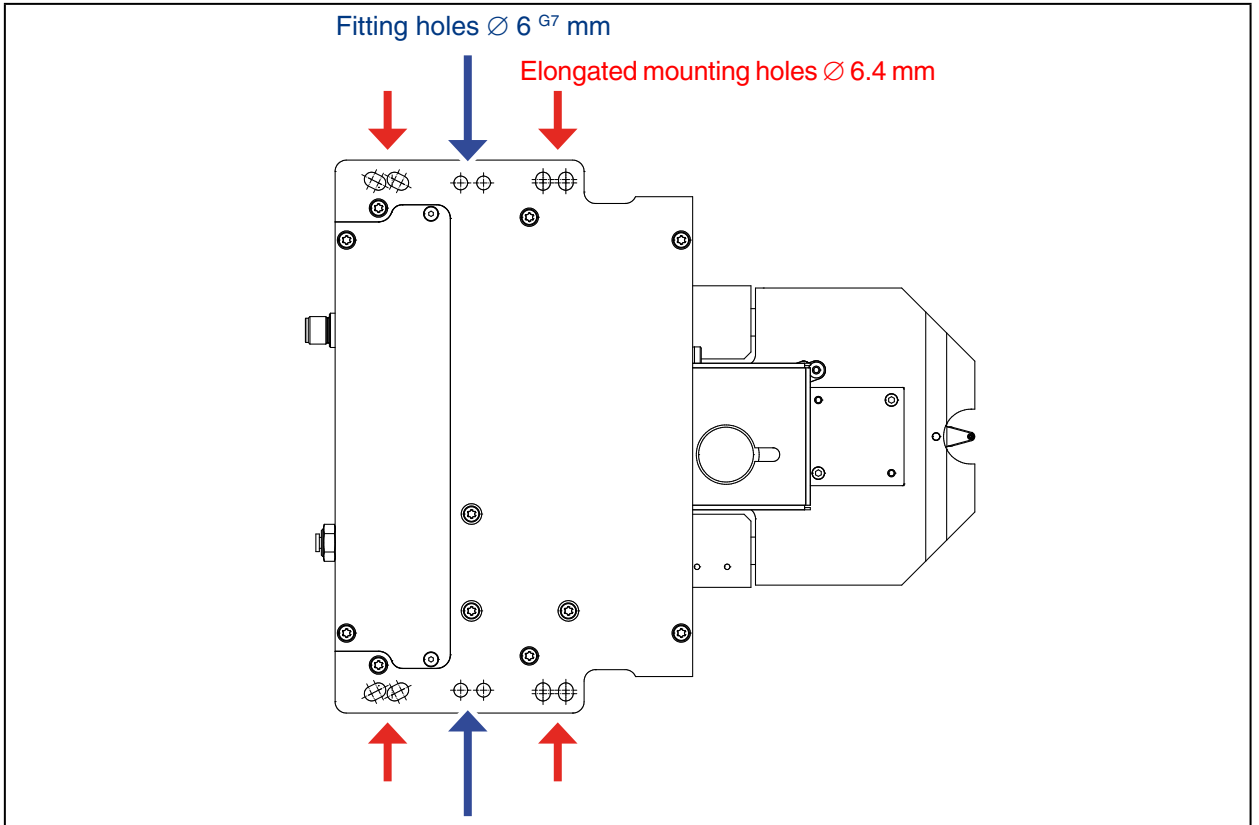

Fig. 5.6: Mounting holes, view from above (same hole pattern below)

6 Electrical connections

The FocusMonitor require a supply voltage of 24 V ±10 % (DC) for the operation. A fitting power supply is part of the scope of delivery. Only use cables with an equipment grounding conductor in order to connect the power supply unit with the local electricity network. The data transmission is based on the Ethernet connection.

A further device, such as a PowerMonitor PM, can be connected to the FM+ via the RS485 interface (PRIMES bus). The signal from the PM is forwarded through the FM+ to the PC via the Ethernet interface. The additional measuring device is electrically supplied via the power supply of the FM+.



Before connecting the PC via the Ethernet interface, you must install the LDS software on the computer (see chapter „Installing the software“ on page 25). The FM+ is used by the software on the computer as a dongle to enable certain software functions.

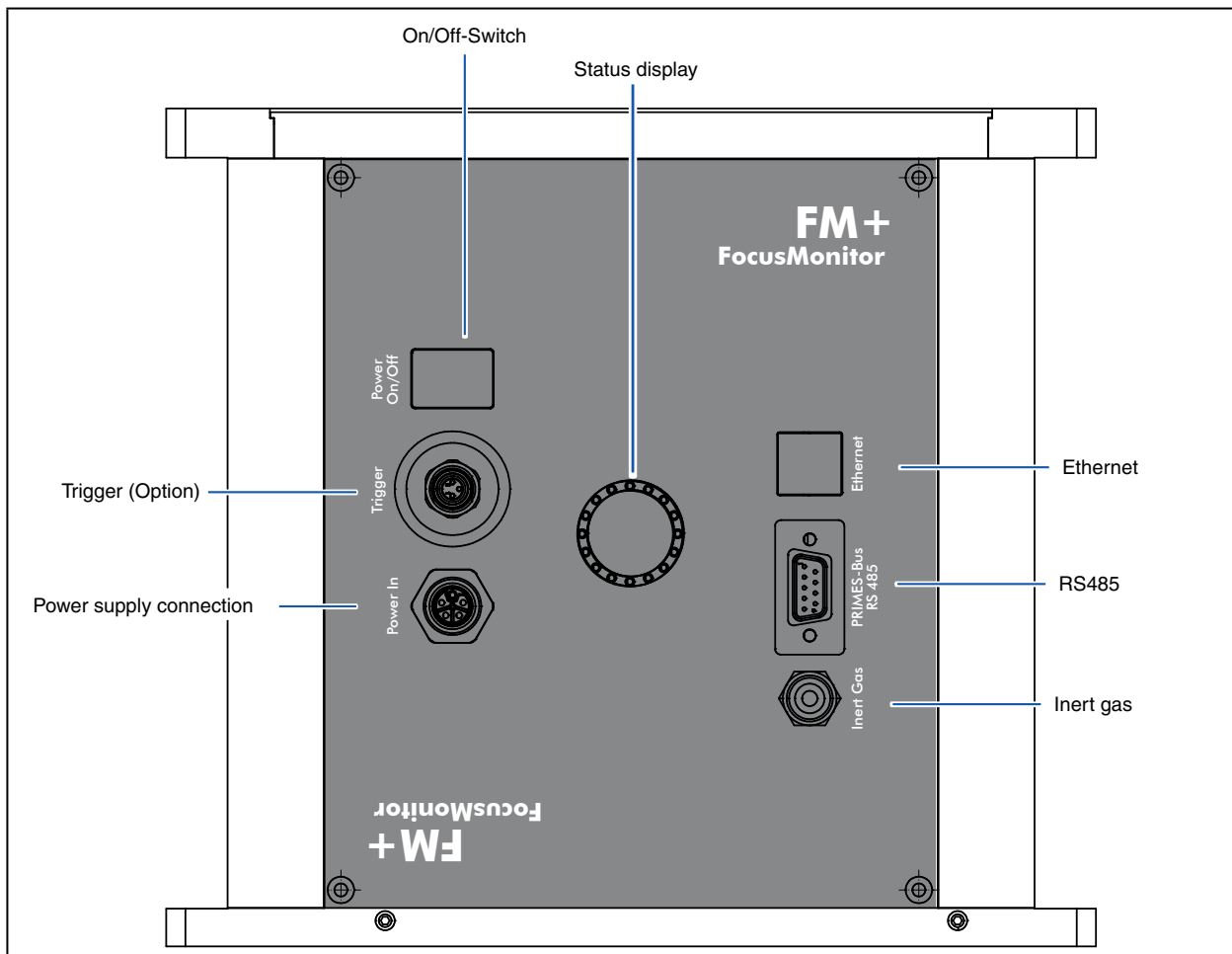
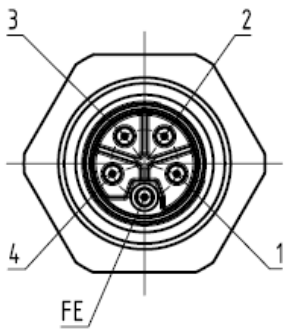

Fig. 6.1: Connections of the FocusMonitor



Please ensure that all electrical connections are established before starting the software!

Power supply connection

Harting M12-P-PCB-THR-2PC-5P-LCOD-M-STR		
	Pin	Function
	1	+24 V
	2	Not assigned
	3	GND
	4	Not assigned
	5	FE

Tab. 6.1: Connection socket for the power supply

PRIMES-Bus

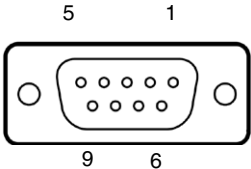
Pole arrangement D-Sub-socket, 9 pole (view of plug-in side)		
	Pin	Function
	1	GND
	2	RS 485 (+)
	3	+24 V
	4	Not assigned
	5	Not assigned
	6	GND
	7	RS 485 (-)
	8	+24 V
	9	Not assigned

Tab. 6.2: D-Submin-socket, PRIMES-Bus

In case you would like to use self-configured cables, please keep the following aspects in mind:

- The length of the cable reaching from the power supply to the measuring device must not exceed 1.8 m. Otherwise the voltage drop of the cable would be too high.
- Please use shielded cable only and observe, that the shielding is efficient continuously.
- The cable length between the FocusMonitor and the second device (via RS485) must neither exceed 2 m.

Trigger output (option)

As an option, the devices can be delivered with a trigger output (24 V). The trigger signal is coupled with the rotation of the disk and, in case of pulsed lasers, it can be used for synchronization. The polarity, the pulse width and the delay of the trigger signal are adjustable.

Pin assignment Binder M8 Series 786/718, 6-pole (view from plug-in side)		
Pin	Function	
1	Trigger +	
2	Trigger -	
3	Rotational pulse	
4	Not assigned	
5	Not assigned	
6	GND	

Tab. 6.3: Trigger socket

6.1 Connection FM+ with the standard power supply and the PC (example)

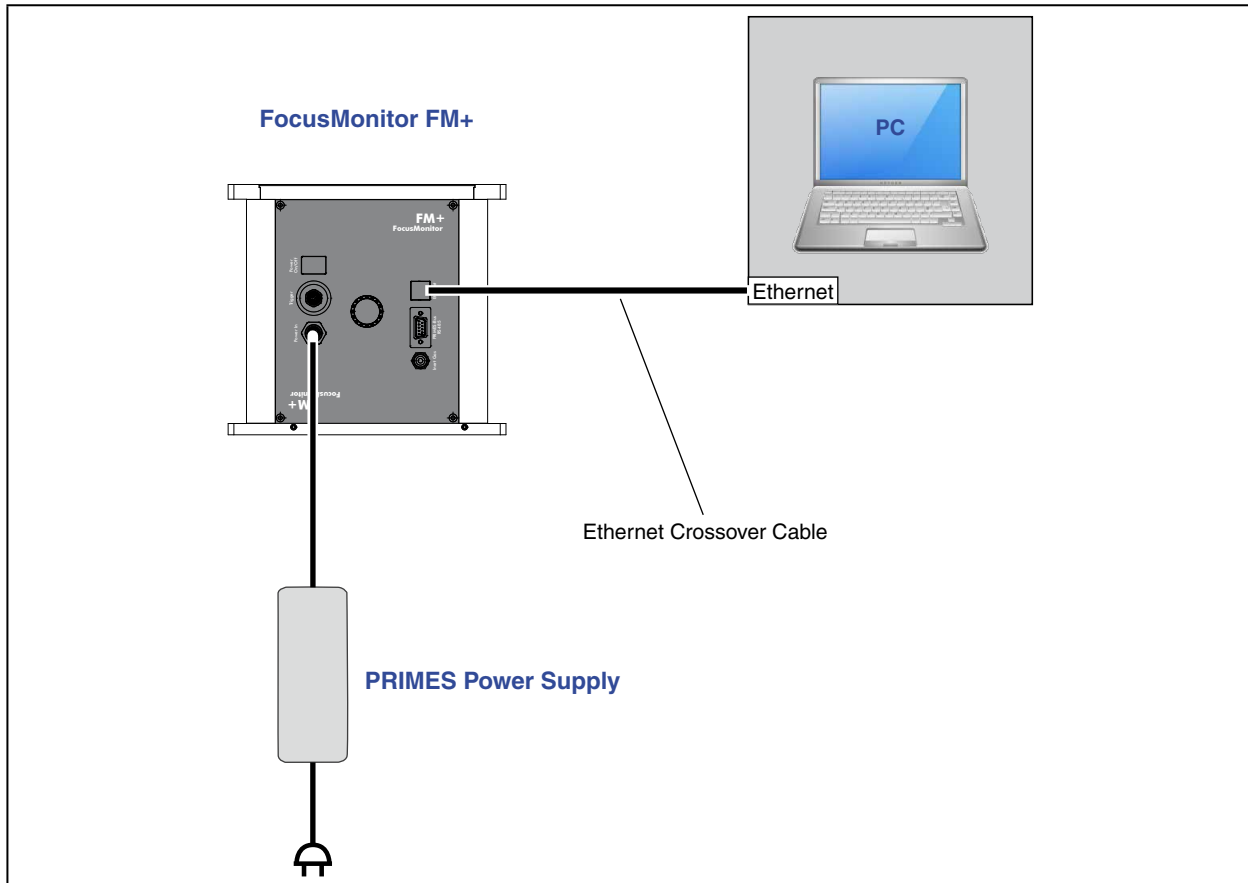

Fig. 6.2: Connection FM+

Connect the FM+ via a cross over cable with the PC or via a patch cable with the network.

6.2 Operation of two measuring devices

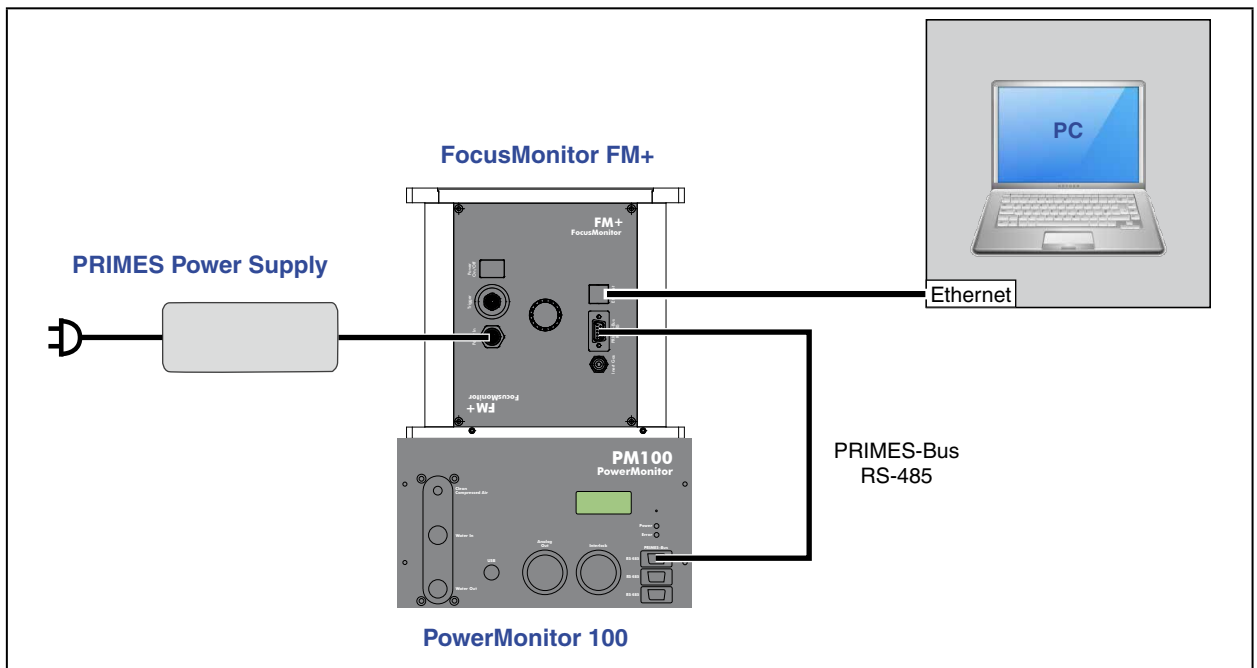

Fig. 6.3: Connection of the FocusMonitor and the PowerMonitor



For connection of several devices please use only one power supply (typically PRIMES power supply).

NOTICE

There is a danger of damage

When disconnecting the bus connections during the operation (when the system is connected with the supply voltage), voltage peaks can develop which could destroy communication modules of the measuring devices.

- ▶ **Please turn off the power supply before disconnecting the bus cables.**

7 Inert gas connection

When measuring high power densities ($\text{CO}_2 > 15\text{-}20 \text{ MW/cm}^2$; $\text{YAG} > 5 \text{ MW/cm}^2$) it is possible that a plasma is ignited on the surface of the measuring tip. This could destroy the measuring tip (see chapter 14.1 on page 81 and chapter 14.2 on page 82). Therefore, a respective protective gas supply is integrated in devices with high power extension (see Fig. 7.1).

NOTICE

There is a danger of damage

The effects of an uncontrolled gas flow (e.g. process gas) could distort the measurement or even damage the device.

- ▶ **Please only use helium, nitrogen or argon as protective gases at the intended connection. The pressure may not exceed a maximum of 0.5 bar.**

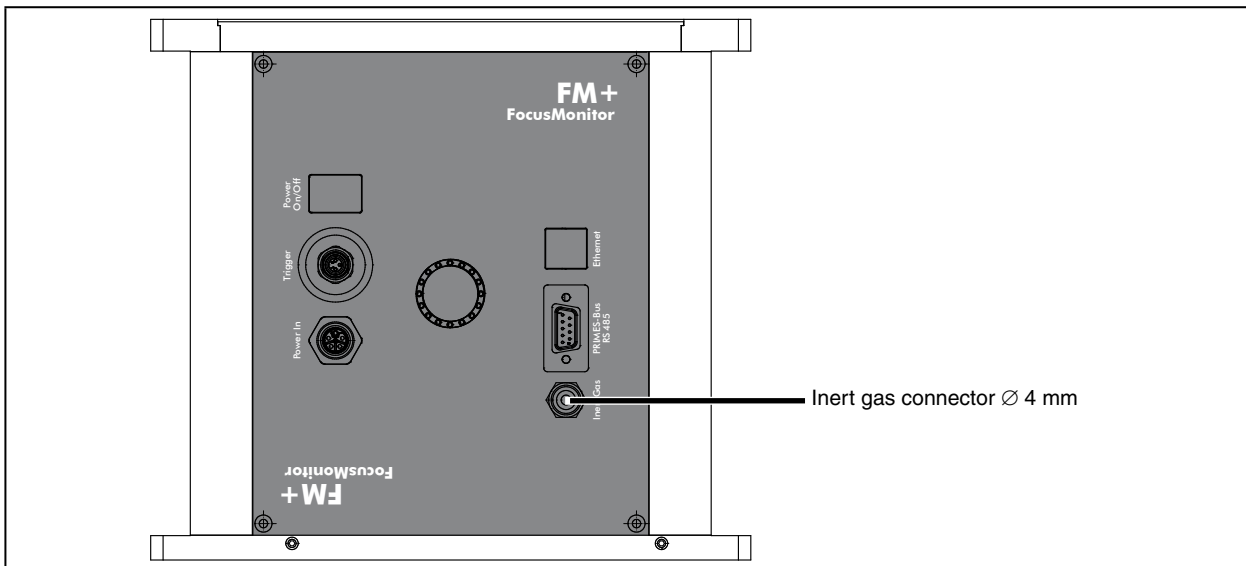

Fig. 7.1: Inert gas connection of the FocusMonitor

8 Status Display

The status display consists of a light ring, which indicates different states of the FM+ by different colors and static or rotating light.

	Color	Lighting state	Meaning
	White	The entire ring illuminates	The supply voltage is applied
	Yellow	Rotating light *	The measuring tip rotates and the different rotational speeds are indicated
	Red	Rotating light *	The measuring tip rotates and the y-axis is moved --> measurement is running, the different rotational speeds are indicated

Fig. 8.1: States of the status display

* The rotational speed of the rotating light simulates the rotational speed of the measuring tip.

9 Software

In order to operate the measuring devices, the “PRIMES LaserDiagnosticsSoftware” (LDS) has to be installed on the computer. The program can be found on the enclosed medium.

9.1 System requirements

Operating system:	Windows® XP/Vista/7/10
Processor:	Intel® Pentium® 1 GHz (or comparable processor)
Free disc space:	15 MB
Monitor:	19“ screen diagonal is recommended, resolution at least 1024x768



When operating on a notebook, please deactivate all power saving functions. Otherwise problems could occur due to the fast serial data transmission.

9.2 Installing the software

The installation of the software is menu driven and is effected by means of the enclosed medium. Please start the installation by double-clicking the file “Setup LDS v.2.98.8.exe” and follow the instructions.

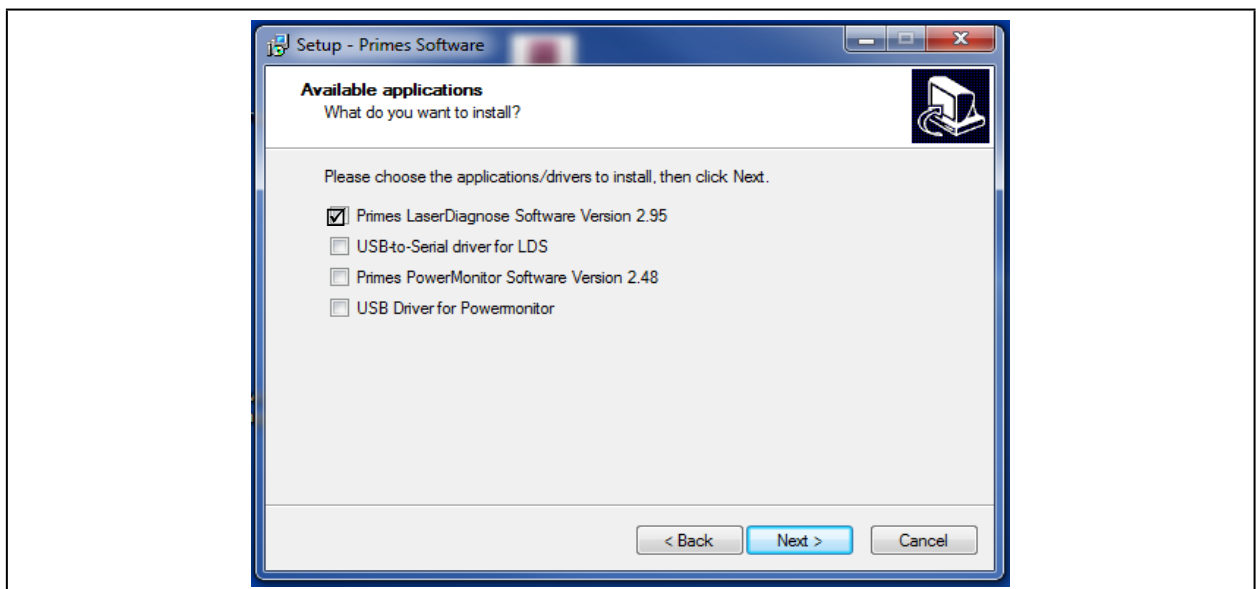

Fig. 9.1: Setup of the PRIMES Software

If not stipulated differently, the installation software stores the main program “LaserDiagnosticSoftware.exe” in the directory “Programs/PRIMES/LDS”. Moreover, the settings file “laserds.ini” is also copied into this directory. In the file “laserds.ini” the setting parameters for the PRIMES-measuring devices are stored.

9.3 Starting the software



Please do not start the software before all devices are connected and turned on.

Please start the program by double-clicking the PRIMES symbol **LDS** in the new start menu group or the desktop link.

9.3.1 Graphical user interface

Firstly, a start window is opened in which you can choose, whether you would like to measure or whether you would just like to depict an existing measurement (factory setting “measurement”).

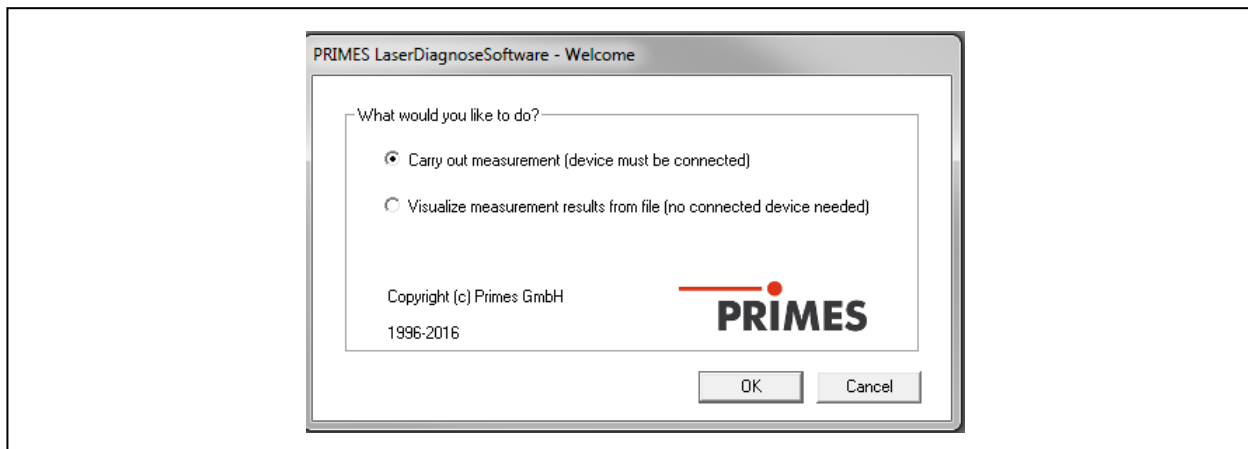

Fig. 9.2: Start window of the LaserDiagnosticsSoftware

After the detection of the connected device, the graphical user interface and several important dialogue windows are opened.

In order to ensure that corresponding information can be assigned quickly, special markups for menu items, menu paths and texts of the user interface will be used in the following chapters.

Markup	Description
Text	Marks menu items. Example: Dialogue window Sensor parameters
Text1>>Text2	Marks the navigation to certain menu items. The Order of the menus is depicted by means of the Sign ">>" Example: Presentation>>Caustic
Text	Marks buttons, options and fields. Example: With the button Start

The graphical user interface mainly consists of the menu as well as the tool bar by means of which different dialogue or display windows can be called up.

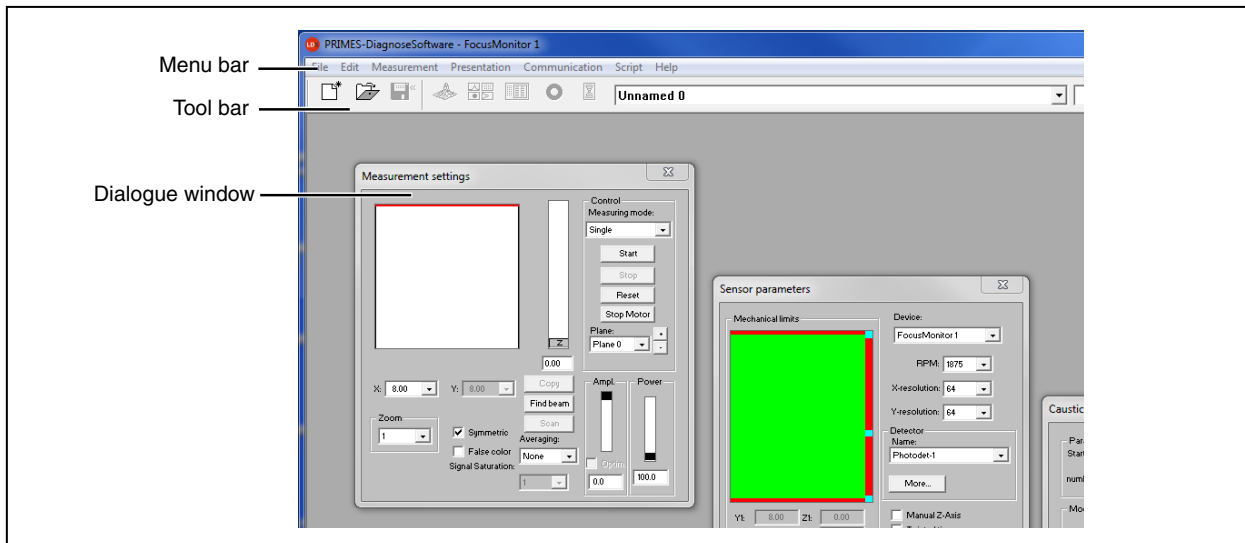

Fig. 9.3: The main elements of the user interface

It is possible to open different measuring and dialogue windows simultaneously. In this case, windows that are basically important (for the measurement or the communication) remain in the foreground. All other dialogue windows are overwritten as soon as a new window is opened.

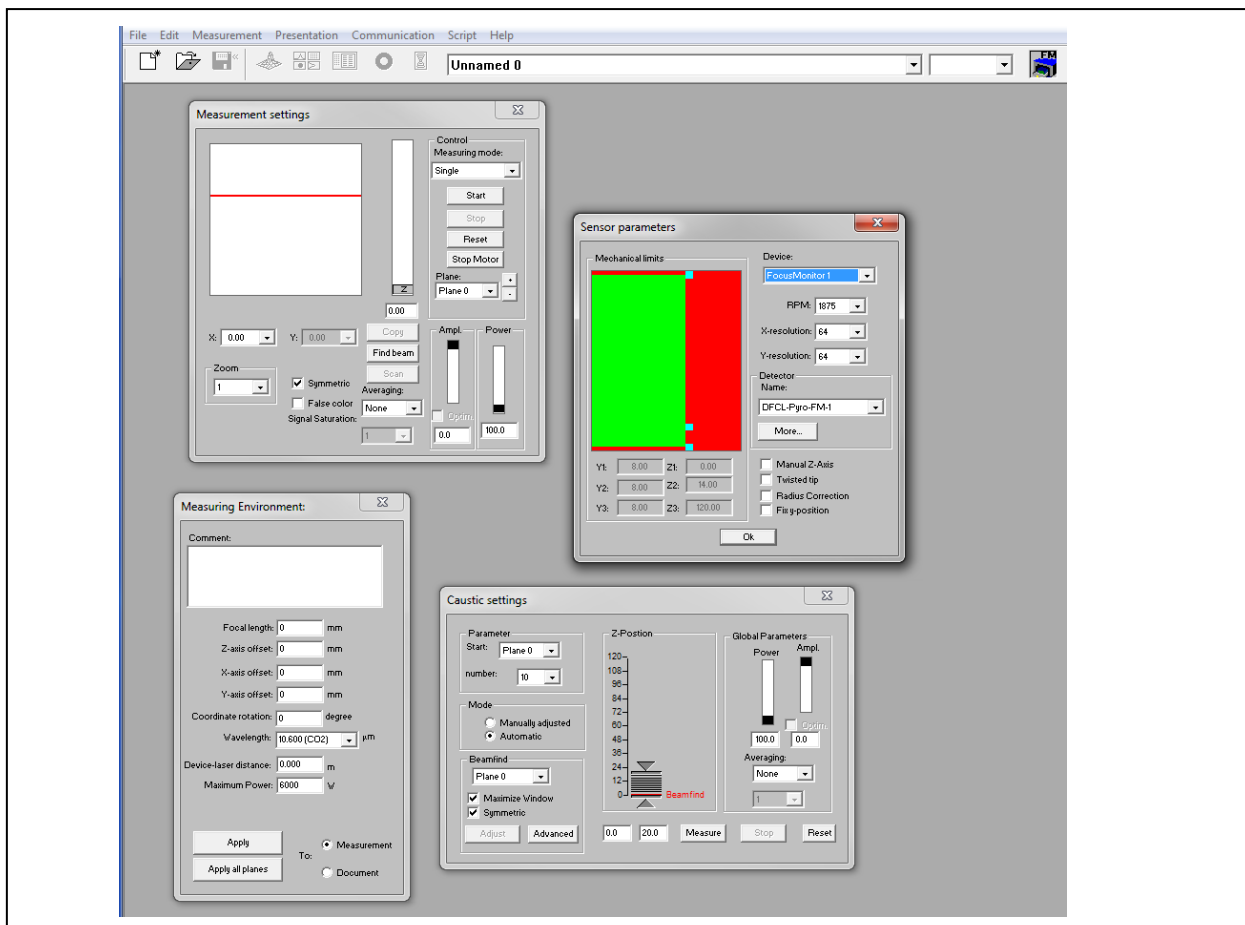
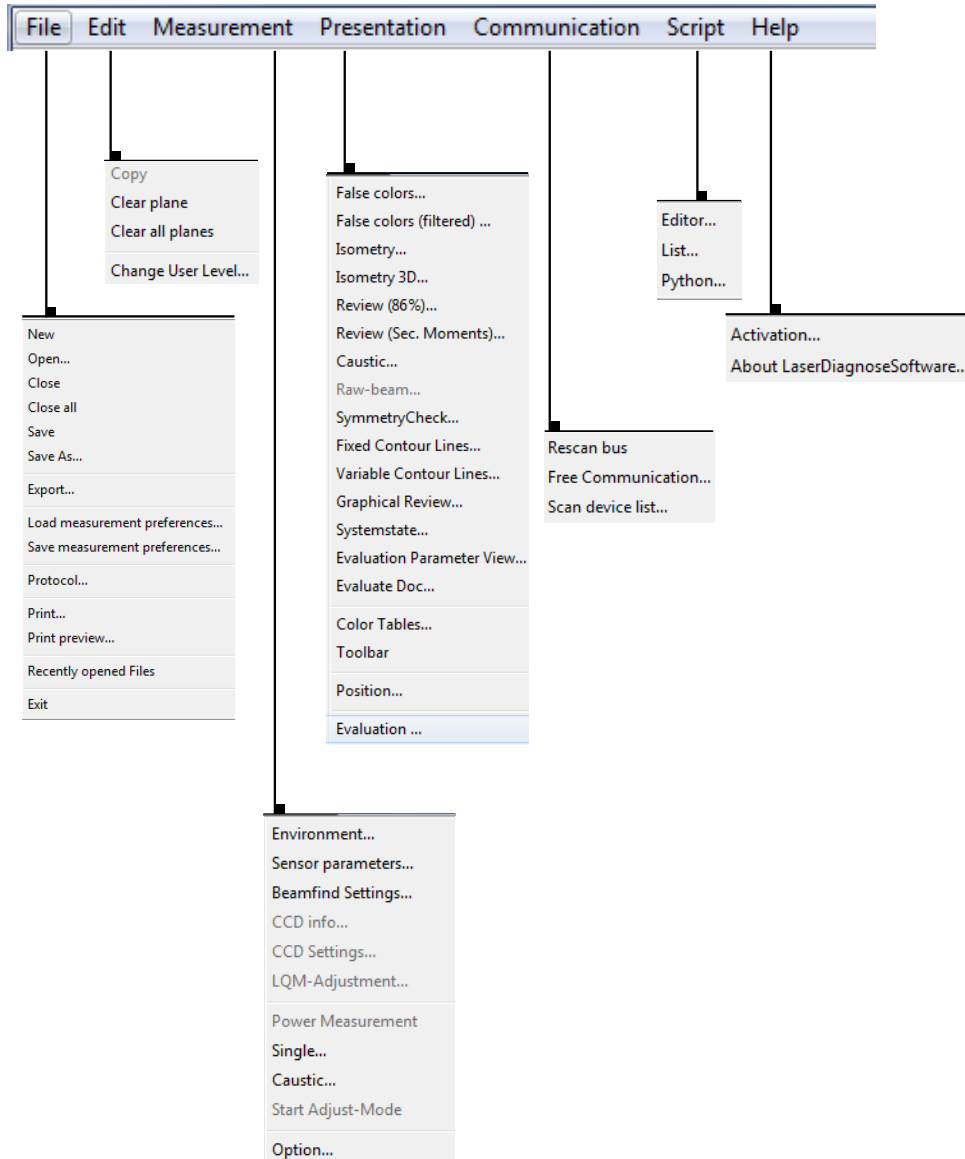

Fig. 9.4: The main dialogue windows

The menu bar

In the menu bar, all main and sub menus offered by the program can be opened.



The tool bar

By clicking the symbols in the tool bar, the following program menus can be reached immediately.

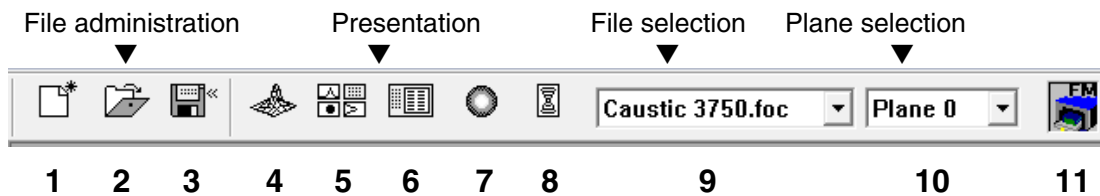

- 1 - Create a new data record
- 2 - Open an existing data record
- 3 - Save the current data record
- 4 - Open the isometric view of the selected data record
- 5 - Open the variable contours line view
- 6 - Open review (86%)
- 7 - Open false color presentation
- 8 - Caustic presentation 2D
- 9 - List with all data records opened
- 10 - Display of the selected measuring plane
- 11 - Display of the measuring devices available for the bus by means of graphical symbols

All measuring results are always written into the document selected in the tool bar (item 9). It is only possible to display documents chosen here. After opening, the data set has to be explicitly selected (please see also chapter „10.2 Presentation and documentation of the measuring results“ on page 48).



Only the device selected in the tool bar is ready for the measurement.

Example:

A FocusMonitor as well as a PowerMonitor are connected with each other via a PRIMES bus. Both devices are turned on and the LaserDiagnosticsSoftware is started. Then, the symbol of the device detected first is activated, e.g. of the FocusMonitor. For a power measurement with the PowerMonitor it is sufficient, to click on the device symbol (PM) in the tool bar. Then you can activate the power measurement via **Measurement>>Power measurement**.

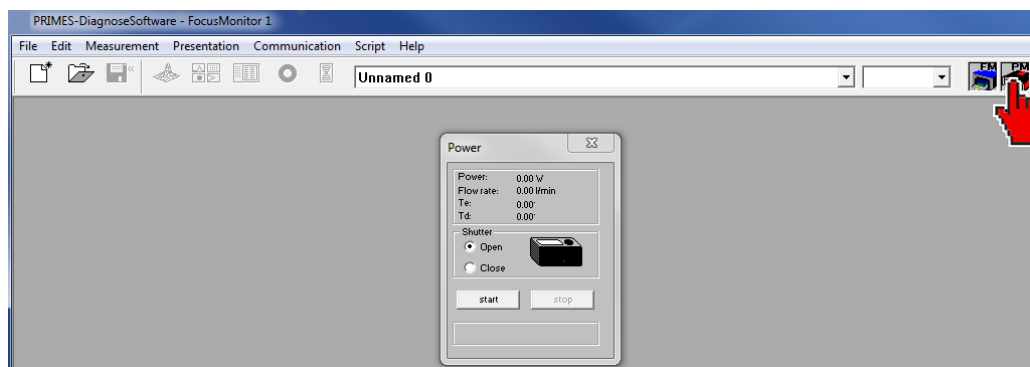

Fig. 9.5: Activating the PowerMonitor for a power measurement

9.3.2 Menu overview

File

New	Opens a new file for the measuring data.
Open	Opens a measuring file with the extensions “.foc” or “.mdf”.
Close	Closes the file selected in the tool bar.
Close all	Closes all files opened.
Save	Saves the current file in foc- or mdf format.
Save as	Opens the menu for the storage of the files selected in the tool bar. Only files with the extensions “.foc” or “.mdf” can be imported safely
Export	Exports all current data in protocol format “.xls” and “.pkl”.
Load measurement preferences	Opens a file with measurement settings with the extension “.ptx”.
Save measurement preferences	Opens the menu to save the settings of the last program run. Only files with the extension “.ptx” can be opened.
Protocol	Starts a protocol of the numeric results. They can either be written into a file or a data base.
Print	Opens the standard print menu.
Print preview	Shows the content of the printing order.
Recently opened files	Shows the file opened before.
Exit	Terminates the program.

Edit

Copy	Copies the current window to the clipboard.
Clear plane	Deletes the data of the plane selected in the tool bar.
Clear all planes	Deletes all data of the file selected in the tool bar
Change user level...	By entering a password a different user level is activated.

Measurement

Environment	Here, different system parameters can be entered, e.g. - Reference value for the laser power - Focal length - Wave length - Remarks
Sensor parameters	The following device parameters can be e.g. set here: - The spatial resolution - The mechanical movement limits in z-direction - Selection of one of the measuring devices connected with the bus - The manual settings of the z-axis
LQM-Adjustment	Not relevant for FocusMonitor
Beamfind settings	Setting parameter for a beamfind procedure. Relevant for FocusMonitor only.
CCD info	Not relevant for FocusMonitor
CCD settings	Not relevant for FocusMonitor
Power measurement	Opens the measuring window power measurement.
Single...	This menu item enables the start of single measurements, of the monitor mode and the video mode.
Caustic...	Enables the start of a caustic measurement. Not only automatic measurements but also serial measurements of manually set parameters are possible. The automatic measurement starts with a beam search and then carries out the entire measuring procedure independently. Only the z-range that is to be examined as well as the desired measuring plane have to entered.
Start adjustment mode	Not relevant for FocusMonitor

Options	Enables the setting of device parameters (advanced users only)
Presentation	
False colors...	False color display of the spatial power density distribution.
False colors (filtered)...	Usage of a spatial filtration (spline-function) on the false color display of the power density distribution.
Isometry...	3-dimensional presentation of the spatial power density distribution.
Isometry 3D...	Allows a 3D presentation of caustic and power density distribution with spatial rotation as well as an optional isophote display.
Review (86%)...	Numerical overview of measuring results in the different layers basing on the 86% beam radius definition.
Review (2. Moments)...	Numerical overview of the measuring results in the different layers basing on the 2nd moment beam radius definition.
Caustic...	Results of the caustic measurement and the results of the caustic fit – such as beam propagation ratio K, focus position and focus radius.
Raw beam...	Not relevant for FocusMonitor
Symmetry check...	Analysis tool to check the beam symmetry especially for the alignment of laser resonators. No standard feature of the devices.
Fixed contour lines...	Display of the spatial laser density distribution with fixed intersection lines for 6 different power levels.
Variable contour lines...	Display of the spatial power density distribution with freely selectable intersection lines.
Graphical review	Enables a selection of graphical displays – among them the radius, the x- and y-position above the z-position and the time.
System state	Not relevant for FocusMonitor
Evaluation parameter	Loading stored evaluation parameters.
Color tables...	Different color charts are available in order to analyse e.g. diffraction phenomena in detail.
Tool bar	In order to display or to hide the tool bar.
Position	Measurement of the FM+ at a defined position
Evaluation	Comparison of the measured values with defined limit values and evaluation (optionally).
Communication	
Rescan bus	The system searches the bus for the different device addresses. This is necessary whenever the device configuration at the PRIMES bus was changed after starting the software.
Free Communication	Darstellung der Kommunikation auf dem PRIMES-Bus. Display of the communication on the PRIMES bus
Scan device list	Lists the device addresses of the single PRIMES devices.
Script	
Editor	Opens the script generator, a tool, by means of which complex measuring procedures are controlled automatically (with a script language developed by PRIMES).
List	Shows a list of the opened windows.
Python	Opens the script generator in order to control complex measuring procedures automatically (script language Python).
Help	
Activation	Enables the activation of special functions
About LaserDiagnostic-Software	Provides information regarding the software version

9.4 Establishing an Ethernet Connection



The FM+ has a stipulated IP address which is given on the identification plate. If the FM+ is switched on before the network is connected, the static IP address is used.

The standard IP address of the FM+ is:

IP Address: 192.168.116.84
Subnet mask: 255.255.255.0

The PC must also have an IP address in the same subnet, for example:

IP Address: 192.168.116.XXX
Subnet mask: 255.255.255.0

The first three blocks of the IP address must match the IP of the FM+ !

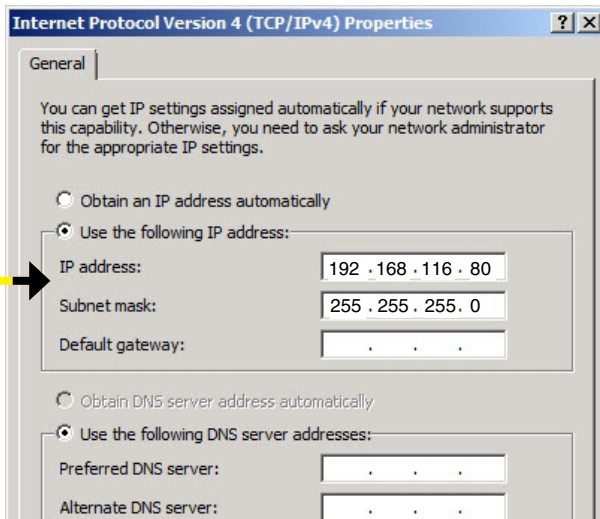

Identification Plate MSM

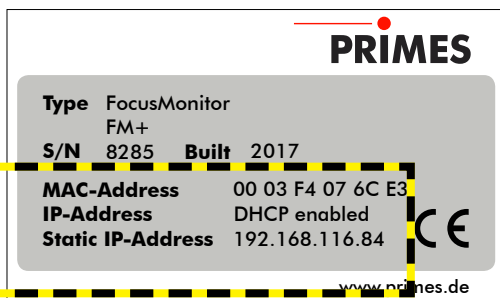

9.4.1 Establishing a connection to PC

1. Please start the PRIMES LaserDiagnosticsSoftware.
2. Open the dialogue window **Communication > Free Communication**.
3. Choose in the field "Mode" TCP (the option "Second IP" must not be activated!).
4. Enter in the field "TCP" the IP Address of your device.
5. Click on the "connect" button ("connected" appears in the bus monitor).
6. Click on the "save" button (the configuration is saved and does not have to be repeated after a restart).

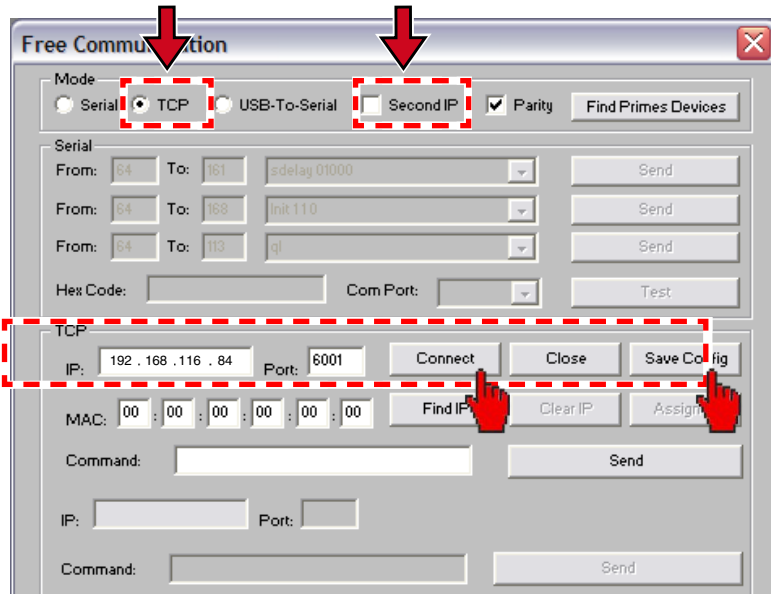

Fig. 9.6: Establishing a connection in the menu **Free Communication**

9.4.2 Changing the IP address

You can change the presetted IP address in the menu **Communication>>Free communication** by means of the following commands:

IP-address (Sample address)	192.	168.	116.	84
	↑	↑	↑	↑
Commands	se0328 *xyz	se0329 *xyz	se0330 *xyz	se0331 *xyz

In this case **xyz** are place holders of the four IP-address bytes (values 1 - 255) which always have to be entered with three digits!

For example, the number 84 has to be entered like this: 084.
For reasons of clarity the symbol * marks a space.

Example: You will change the IP address from 192.168.116.85 to 192.168.116.86.

1. Please start the PRIMES LaserDiagnosisSoftware.
2. Open the menu **Communication>>Free Communication**.
3. Choose the mode "TCP" (the option "second IP" must not be activated!).
4. Enter the IP in the field "TCP".
5. Click on the "connect" button ("connected" appears in the bus monitor).
6. Activate the checkbox **Write bus protocol** (the protocol can be helpful in case of problems).
7. Enter the following in the field **Command** (please make sure that the blank character * is entered correctly):

se0331*086

8. Click to **Send** and wait for the confirmation in the bus monitor (in Fig. 9.7 „-> Adr:0331 Wert: 086“)
9. Please turn off the device and turn it on again. After this restart the IP-address is updated.

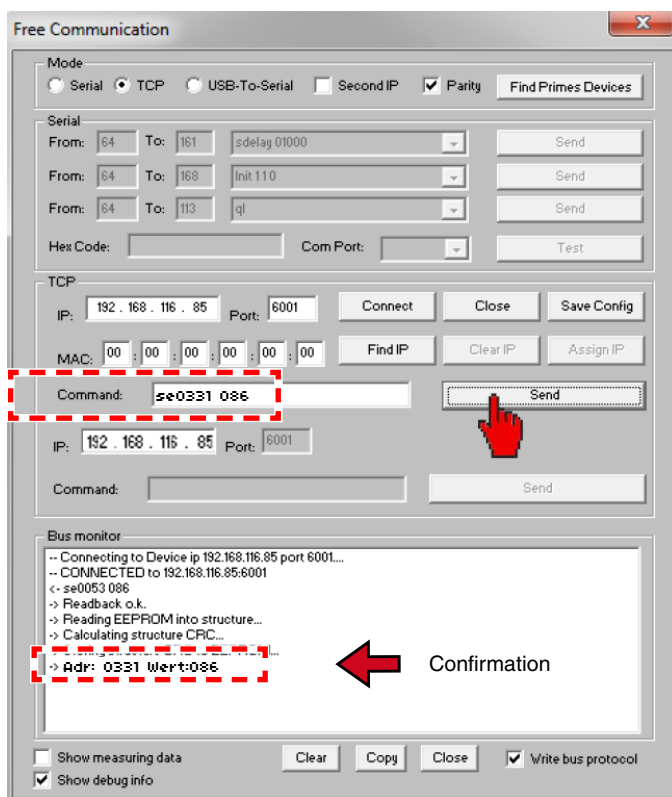

Fig. 9.7: Changing the IP address in the menu **Free Communication**

10 Software functions in detail

The LaserDiagnosticsSoftware is the control centre for all PRIMES measuring devices which measures the beam distribution as well as focus geometries by means of which the beam propagation characteristics can be determined. The LDS includes all functions necessary for the control of measurements and displays the measuring results graphically.

Moreover, the systems uses the measured data to carry out an evaluation in order to give the operator of the beam diagnosis an information regarding the reliability of the measuring results.

10.1 Settings

Due to the fact that the LDS is designed multifunctionally for all PRIMES devices, a few device-specific settings have to be made before a measurement. Moreover, the system and beam geometry provided by the customer are to be considered.

10.1.1 Sensor parameter

Mechanical limits

Many laser processing systems restrict the movement range of the FocusMonitor by means of nozzles and pressure rolls. Especially in case of cutting applications it is obligatory to demount the nozzles as the measurement of the upper part of the caustic is otherwise not possible.

If they are not demounted, the movement of the measuring system has to be restricted in order to prevent collisions with the measuring device. This is possible in the field **Mechanical limits** of the dialogue window **Sensor parameter** (please see Fig. 10.1). With the three adaptable squares in the restriction window the movement range can be restricted in y and z direction.

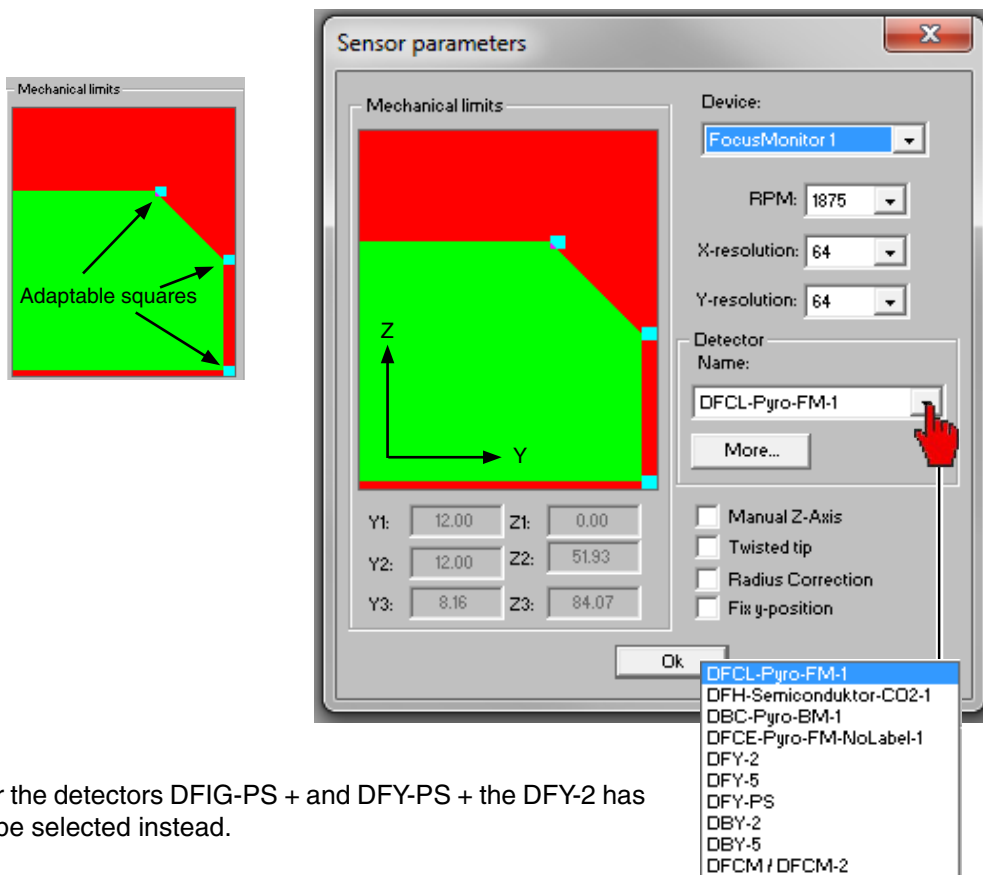

For the detectors DFIG-PS + and DFY-PS + the DFY-2 has to be selected instead.

Fig. 10.1: Dialogue window **Sensor parameters**

Device

By means of this option, you can select the device which is supposed to be operated. Depending on the number of devices connected, additional device numbers are assigned.

RPM (rotations per minute)

In case of the Focus Monitor, the rotations per minute of the measuring tips can be increased for the work with high and highest power densities. The basic value is 1875 rotations per minute. For high power densities you can work with 3750 rpm and for highest densities – with many devices – even with 7500 rpm. Optionally even further revolution speeds are possible.



If you change the resolution or the rotations per minute, you have to initiate a reset cycle to ensure that the settings are accepted by the device.

Resolution

Possible settings:

- 32 x 32 up to 1024 x 1024

Generally, 64 pixels per line and a total of 64 lines is sufficient. The resolution in y-direction stipulates the number of lines and the resolution in x-direction the number of scanning points per line. The measuring time gets longer if the number of measuring tracks increase. In case of 64 x 64 pixels the minimum distance between two measurements with regard to the time is 8 to 9 seconds.

The time for the data transfer depends on the amount of data and on the interface. The amount of data increases with a higher resolution. The performance of the computer also has an influence on the data transfer time. Please note the following dependence of the minimum window size on the selected revolution speed and resolution.

Minimum beam size for the FM+ is about 100µm windows smaller than 250µm should be avoided. Since the minimum beam radius is 100 µm, the crossed out values are not recommended:

Revolution speed in rpm	x-resolution in pixel	Minimum window size x and y in mm
1875	32	0.02
	64	0.04
	128	0.08
	256	0.16
	512	0.33
	1024	0.65
3750	32	0.04
	64	0.08
	128	0.16
	256	0.33
	512	0.65
	1024	1.31
7500	32	0.08
	64	0.16
	128	0.33
	256	0.65
	512	1.31
	1024	2.62

Tab. 10.1: Minimum window size

Detector

There are different detectors for the different applications and special wave-lengths. In order to compensate for the different time response of the detectors employed, the selection of the right type of detector is necessary. (Presettings in the file "laserds.ini"). For the employment of CO₂-semi-conductor detectors, it might be necessary that the compensation parameters are adjusted manually in accordance with their marking. The respective dialogue window can be opened by clicking the button **More**.

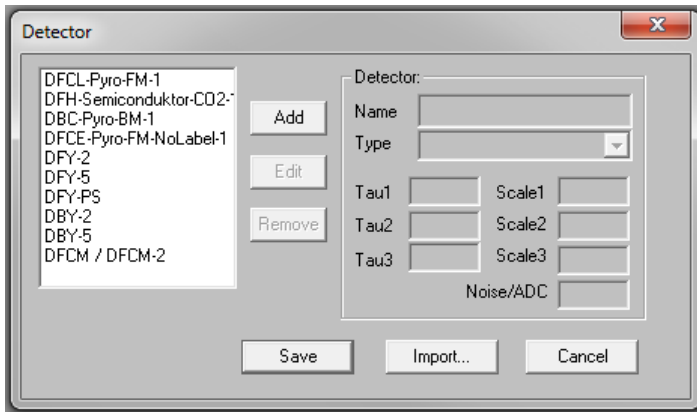

Fig. 10.2: Dialogue window for the adaption of CO₂ semi-conductor Detectors

A selection table of the detector types can be found in chapter „14 Variety of Detectors and Measurement Tips“ on page 79.



After changing the sensitivity of the detector, you have to reset the device by turning it off and on again.

Manual z-axis

Please activate this option if the z-position of the measuring plane is not run by the internal z-axis. In this case, please enter the z-values for each plane manually in the menu **Measurement settings >> single measurement**. The software then carries out a caustic analysis on the basis of the determined beam radii and the z-values.

The beam propagation ratio can also be determined this way, using the measured data of the unfocused beam in different distances from the beam source.

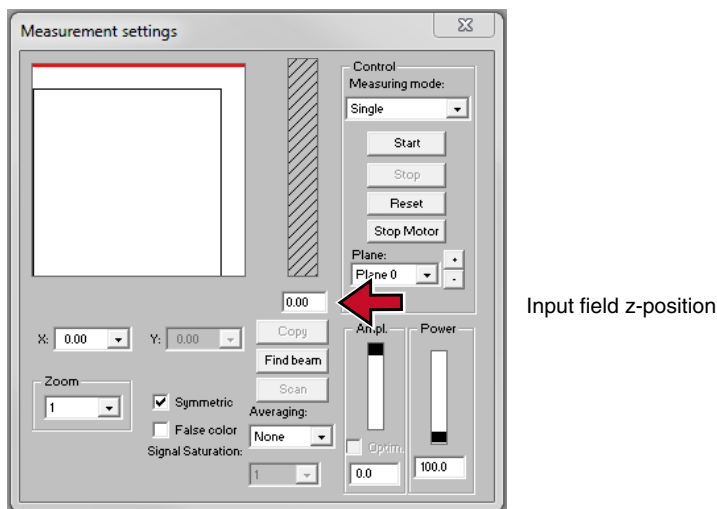

Fig. 10.3: Manual entry of the z-position

Twisted tip

Please activate this option if you work with a turned by 180° measuring tip. The x-axis is then turned internally (see Fig. 10.4).

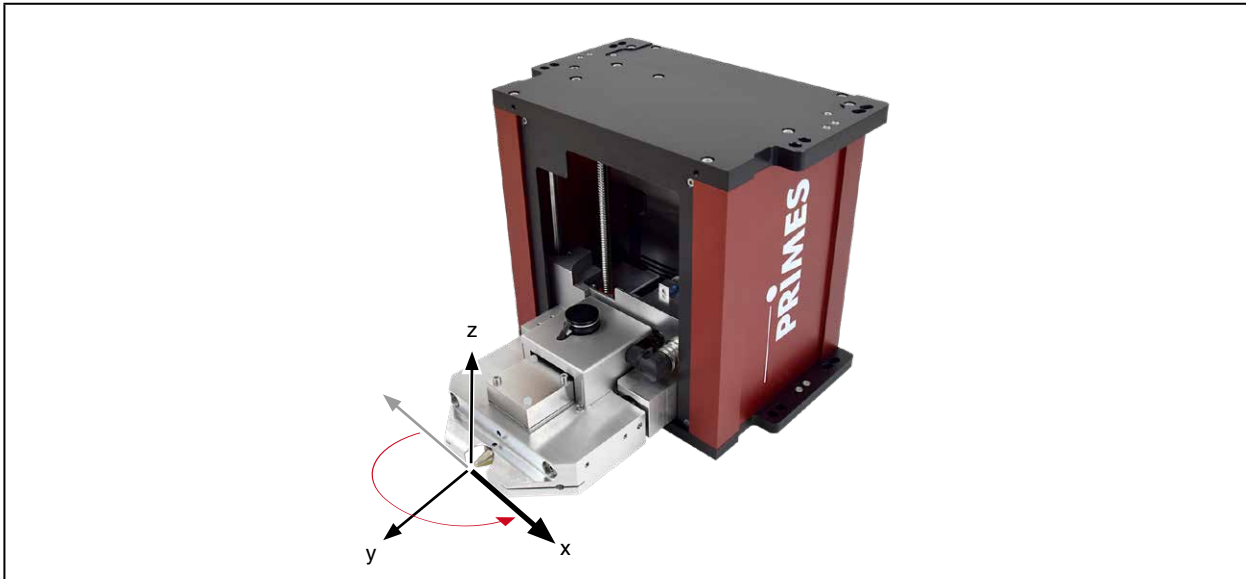

Fig. 10.4: Coordinates for a turned measuring tip

Radius correction

Activate the radius correction when measuring rectangular or linear laser beams. This option compensates the curvature of the scanning tracks.

10.1.2 Measuring Environment (menu **Measuring**>>**Environment**)

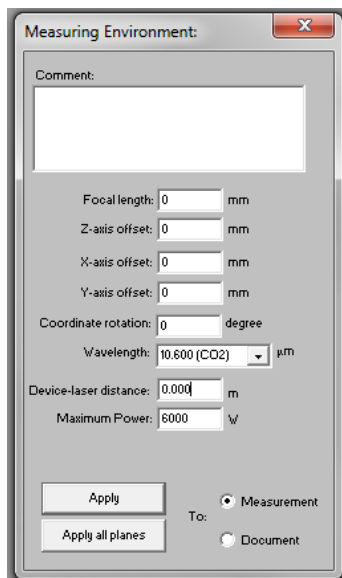

Fig. 10.5: Dialogue window **Measuring environment**

In the dialogue window **Measuring Environment** data such as the laser type, information on the focusing optic etc. can be stored (the input field **Device-laser distance** is not relevant for FocusMonitor. These data can be read via **Presentation**>>**Review**.



Please note that the symbol # must not be entered in the comment field. This symbol is used as a separator in the software. If it is entered in the comment field, problems could occur when it comes to storing or activating measuring data..

A line break can be enforced by means of the following key combination:

<Ctrl> + <Enter>

Entering the laser power is a reference value for the relative power position in the menu point **Single measurement** or **Caustic measurement**. Stating the focal length is relevant for the evaluation of the caustic measurements. From the caustic process and the entered focal length the raw beam diameter on the focussing optic can be calculated.

Furthermore, a z-axes offset as well as a coordinate rotation angle can be entered. The wave-length is the basis for a correct determination of the beam propagation ratio.

There are the following options:

- 10.6 μm for die CO₂ - laser radiation
- 1.06 μm for Nd:YAG - laser radiation
- 0.632 μm for HeNe - laser radiation.

A μm-value can also be typed in numerically.

By means of the button **Apply** the entries can also be changed after a measurement. With the button **Apply all planes** the entered values are inserted and settled, while the button **Apply** only refers to the value in the current plane.

10.1.3 Beam find (Menu **Measurement**>>**BeamFind settings**)

Here, the parameters for the automated beam find are set. The general presetting is helpful for many standard applications.

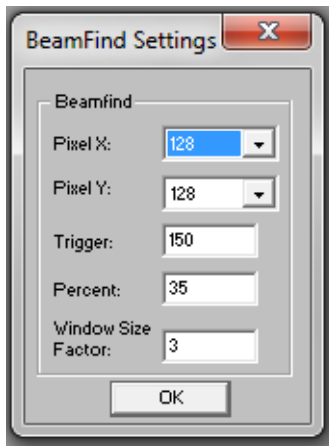

Fig. 10.6: Dialogue window **BeamFind settings**

The Beam find parameters can be set as follows:

Pixel X, Pixel Y

- The selection of the spatial resolution. Search problems can occur with regard to very small beams with 64 x 64 pixels in a 8 mm x 8 mm window, as the pixel distance is about 120 μm . In this case we recommend the enlargement of resolution.

Trigger

- The signal threshold (Trigger) is dependant on the zero level of the measuring system.

Percent

- The percentage value indicates by how much the signal has to exceed the zero level in order to be recognized as a beam. This value is determined by means of the signal-to-noise ratio of the detector.

Window Size Factor

- The window size factor determines the size of the measuring window when it comes to the beam search. The factor indicates how big the measuring window has to be in relation to the beam diameter.

10.1.4 Single measurement (menu Measurement>>>Single measurement)

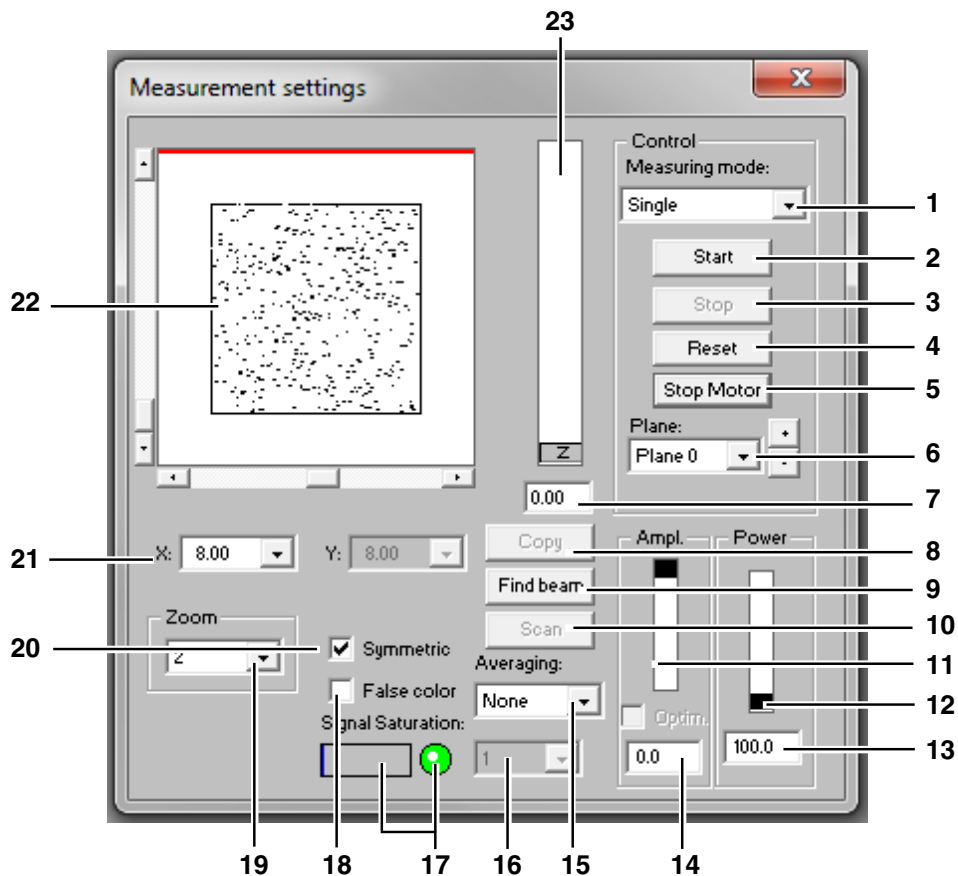

1	Single Monitor LineScan (option)	Starts a measurement in the chosen plane Starts repeated measurements in the chosen plane automatically Starts a measurement of a single trace with fixed y-axis
2	Start	Starts a measurement in the currently chosen plane
3	Stop	Finishes the measurement in the currently chosen plane
4	Reset	The measuring device is reset
5	Stop Motor	Stops the rotating measuring tip after the measurement is finished
6	Plane	Selection of the measuring plane (0-49) either explicit or by means of the buttons (+/-)
7	Entry field	Numerical entry of the z-position
8	Copy	Copies all settings (window size and – position; x, y, z; etc.) from the former plane to the current plane (e.g. 1>>2)
9	Find beam	Starts an automatic beam search in the current measuring plane
10	Scan	Not relevant for FocusMonitor
11	Ampl.	Slide control in order to adjust the electrical amplification
12	Power	Slide control in order to adjust the laser power to save it in the software
13	Entry field Power	Numerical input of the laser power to save it in the software
14	Entry field Ampl.	Numerical input of the electrical amplification
15	Averaging	Analysis of the serial measurements. Averaging algorithms: average value, values of the maximum pixels and the value of the maximum trace
16	Averaging	Selectable number (1 – 50) of single measurements for the averaging
17	LED symbol and bar graph display	Display for the degree of the signal saturation (LED green△ok, red△not ok)
18	False color	Activates the option of the false color presentation
19	Zoom	Magnification settings for the measuring window
20	Symmetric	This option enforces the usage of square measurement windows, whose size is only adjustable via x.
21	X/Y	Setting of the size of the measuring window
22	Display	Measuring window shows the current measuring result.
23	Z	Slide control in order to set the z-position

With this dialogue window either single measurements or repeated measurements can be carried out. The measuring mode Monitor starts a continuously repeating measurement with current settings. The repetition rate is dependant on the spatial resolution as well as the rpm. With 64 x 64 pixels and 1875 rpm the measuring time is about 10 seconds. The monitor operation can be terminated by clicking the button **Cancel** in the status window (in the bottom right corner of the screen).

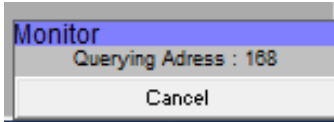

Fig. 10.7: Status window

The measuring window position can be set either manually or automatically.

With the button **FindBeam** the measuring window of the FocusMonitor is set automatically. In this case, the system only searches in the range given in the currently set window in the set z-position. Afterwards the window **FindBeam** appears.

In case the beam search is completed successfully, a measurement window with the found beam in the measuring field of the single measurement window appears. However, at that point the window size is not yet optimized. With the button **Start** the beam can then be recorded.

As far as the manual beam search is concerned the position as well as the size of the measuring window within the mechanical limits can be stipulated by the operator. The choices can be made in a pop-up menu, where [x] for square measuring windows or respectively [x] and [y] for rectangular are to be stipulated. The maximum size of the measuring windows is - in case of the FocusMonitor – in the standard configuration 8 mm x 8 mm (optional up to 24 mm x 12 mm).

The position of the measuring window is changed by clicking on the frame and moving it by means of the mouse. The position of the window in z-direction (height) can be stipulated by means of the z-slide control or by means of a numerical entry. The zoom function enables a detail enlargement in the measuring window.

Size of the measuring window

In order to minimize the measurement errors, we recommend a measuring window size which ensures that the beam diameter equals 30 % to 70 % of the base side length of the measuring window. The distribution has to be preserved at full extent without a restriction by the border of the measuring window.

Electrical amplification

The power density distribution is measured by a detector. Its analogue output signal is amplified and then digitalized. There are different detectors available (see Tab. 14.2 on page 80)

In case the detector overamplifies (red LED symbol in the display for the signal saturation or – respectively – a ADC value of 4095 in the presentation **Variable Contour Lines**), please reduce the amplification by means of the slide control “ampl.” and repeat the measurement.

Not only an overamplification but also a low amplification lead to unsecured or false results. We recommend the readjustment of the amplification in order to receive correct results.

Laser power

The laser power can not only be set by means of the slide control but by entering it numerically. The reference value for the laser power is entered in the dialogue window **Measurement>>Environment**. The calculation of power densities refers to the power values set here.

Please click on the button **Start** to start the measurement.

Up to 50 single measurement planes can be part of one measuring file. This is relevant for measurements of the beam caustic as well as for time or power series. It is possible to switch for presentation between the individual measuring planes.

With the button **Copy** the measurement settings (window size and position, power and amplification) can be copied from the previous measuring plane.

By means of the option **Averaging** the average of the results of up to 50 single measurements per each plane is determined. There are different analysis algorithms available:

Selection	Function
Average	determines the average value of the distributions measured
Max. pixel	determines the pointwise maxima of the distributions measured
Max. trace	determines the maximum traces of the distributions measured

The selection **Max. pixel**, **Max. trace** are especially helpful when it comes to pulsed laser radiation. The radii determined in case of **Max. pixel** are not always reliable due to zero point uncertainties.

During a measurement, the status of the measurement system is constantly displayed. These are:

- the current measuring plane
- the run of the reference cycle
- positioning the measuring head
- the measurement
- the data transmission – the progress is shown by means of the bar display

By means of the button **Stop** you can cancel a running measurement which also ends the monitor operation. Please click on the **Reset** button afterwards.



If you interrupt the data transmission by clicking on the **Reset** button, you have to reselect the ComPort in the menu **FreeCommunication**.

With the button **Stop Motor** the rotation of the measuring tip is stopped after the completion of the current measurement. Please click the Reset button afterwards.



CAUTION

Danger of injury due to rotating parts

The measuring tips of the FocusMonitor keep rotating for a short period of time after the supply voltage was turned off.

- ▶ **Do not reach into the entrance of the measuring device and do not hold any items into it, as long as the measuring tip is rotating.**

10.1.5 Caustic measurement

The caustic measurement is a serial measurement where the z position is varied. The results are stored in different planes. A different z position is assigned to every measuring plane. As the beam radius as well as the power density change in every z position, the position as well as the size of the window and the signal strength can vary from plane to plane. These parameters are therefore individually adjustable in every measuring plane.

NOTICE

Danger of damage due to an over-temperature

Please note that serial measurements can sometimes take much longer in comparison with your production process and that the optic is not cooled by the process gas stream during this period.

► **In this case, please ensure an adequate cooling of optical components!**

The results of a focus measurement could be distorted by non-cooled optics. The caustic measurement itself can be carried out either manually or automatically.

The caustic measurement itself can be carried out either manually or automatically.

Preparing a caustic measurement

After the correct mounting of the FocusMonitor, the beam focus should be in the middle of the movement range of the z-axis (please also see chapter 5.3 on page 17).

Automatic caustic measurement

For the automatic caustic measurement the following has to be entered:

- the laser power
- the amplification
- the number and type of averaging
- the minimum and maximum z-position (if typed in numerically, please enter the higher value first)
- the number of planes that are to be measured (minimum 15)
- the starting plane for the beam search

In order to start the measurement cycle please click on the button **Measure**. The measuring planes are then measured one after the other.

The measurement cycle starts with an automatic beam search in the chosen starting plane. The first beam find is typically carried out with a maximum window size of 8 mm x 8 mm. If the size of the search window is not supposed to equal the maximum window size, please proceed as follows:

1. Deactivate the option **Maximize Window**
2. Click on the button **Adjust**
3. Type in the desired window size (X/Y)

Click on the button **Advanced** in order to adjust the beam search parameters with regard to the spatial resolution, the threshold height (trigger) and the minimum signal height (please also see chapter 10.1.3 on page 40).

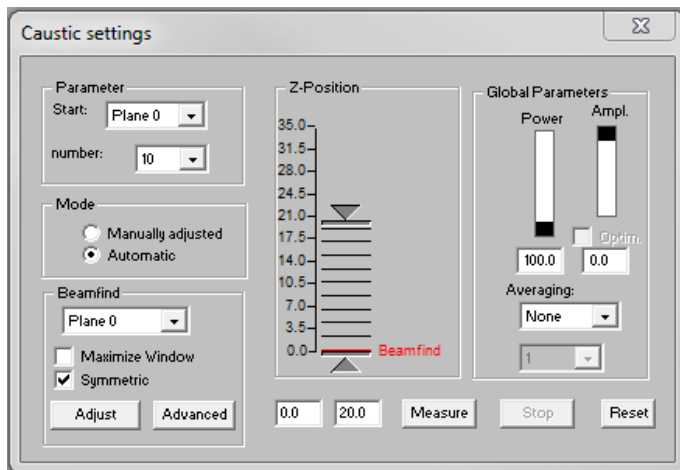

Fig. 10.8: Dialogue window **Caustic settings (Automatic)**

You can store the adjusted measuring parameters – window size, window position etc. – in a file and – if needed – load them again (**File>>Measurement preferences store/load**).

Manual caustic measurement

Recommended settings:

In the range of each two Rayleigh lengths on either side of the focus a minimum of 10 measuring planes should be created. At least five of them should have a distance of \pm one Rayleigh length around the focus. Another five ones should have a distance of at least two Rayleigh lengths from the focus.

For a measurement which is in conformity with the regulation (ISO 11146) it has to be effected over at least four Rayleigh lengths. It has turned out that five to six Rayleigh lengths with about 15 measuring planes are highly practicable. In case of an unknown beam geometry, you should carry out some individual measurements first for orientation before starting an automatic caustic measurement.

The manual caustic measurement consists of a succession of single measurements at different z-positions. The measurement results are then each stored in an individual plane.

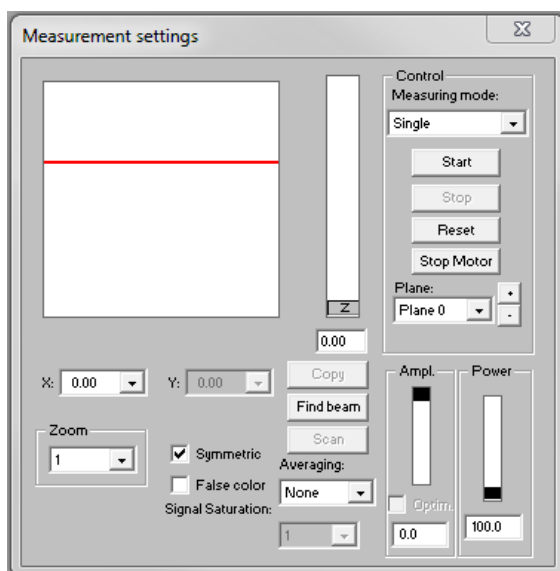

Fig. 10.9: Dialogue window **Measurement>>Single**

For the manual caustic measurement the following steps are necessary:

1. Please choose the menu item **File>>New**
2. Please choose the menu item **Measurement>>Single...**
3. Please choose the first plane
4. Please adapt the z-position
5. Please adapt the window size as well as the position
6. Please click the button **Start**
7. Please choose the next plane, click the button **Copy** and continue with point 4.

Please repeat the steps 3 to 7 about 10 to 15 times.

Please choose the option **Manual settings** in the menu item **Measurement>>Caustic** and click the button **Measure**.

Then the different planes are measured with the parameters set.

The measuring parameters can be stored by means of the menu item **File>>Save measurement preferences** and can be loaded again upon request.

As a z-distance of the single planes we recommend a value which makes up about 0.5 % of the focal length. In case of a focal length of 5" (127 mm) this equals about 0.5 mm up to 0.6 mm.

For caustic measurements with 15 planes a range of about 8 mm is covered on the z-axis.

Cyclical caustic measurements

In case of cyclical caustic measurements it makes sense to store the settings of the different recording parameters in a file. These data are then available at all times and can be used for new measurements. For a "fast" control of the beam a measurement with only a few planes is recommendable. If needed, it is also possible to measure only a part of the caustic as, for example, the gas nozzle is still mounted.

Such a measurement cycle takes approx. 2 to 3 minutes. For this case, it also makes sense to connect the FocusMonitor with the system control via the PLC Interface so that the activation as well as the deactivation of the laser can be program-controlled and effected by the LaserDiagnosisSoftware. For control measurements after a laser or a system maintenance, a measurement with more planes is recommendable as the measuring results are here determined with a higher accuracy

Before the measurement, stored setting data of the caustic are loaded from a pre-configuration file (**File>>Load measurement preferences**). After entering the desired file name the respective data are loaded. The measurement itself is then effected as a manual caustic measurement.

Options

This menu should be used only by advanced users. Please keep in mind that most of the items are not relevant for FM+.

The only exception is the presentation of the beam dimensions, which allows to switch from radius to diameter, see Fig. 10.10.

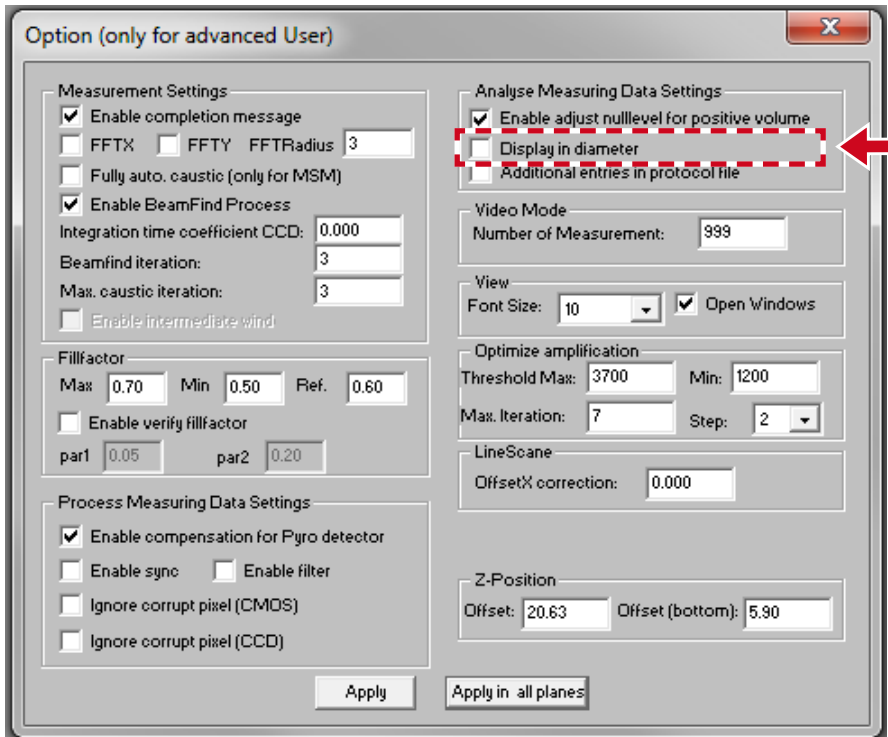

Fig. 10.10: Setting for the display of the diameter

10.2 Presentation and documentation of the measuring results

This chapter describes the presentation, analysis and storage of measuring results.

In order to carry out comparisons between different measurements, the program can manage several measuring data sets simultaneously. The opened data sets are shown in the tool bar. In order to open one presentation, the data which is to be examined is selected in the list of the data selection and afterwards the desired kind of presentation is chosen.

By clicking on the symbols of the tool bar the following program menus can be reached.

Toolbar of the LDS

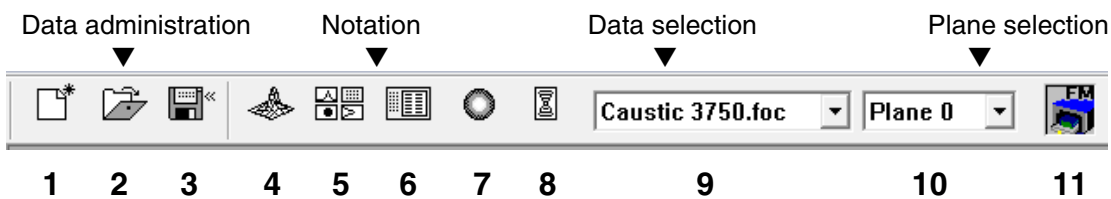

1. Create a new data set
2. Open existing data set
3. Save data set
4. Open isometry presentation of selected data set
5. Open variable contour lines display
6. Open review (86 %)
7. Open false color presentation
8. Caustic presentation
9. List containing all data sets opened
10. Display of the chosen measuring plane
11. Display of the devices available at the bus by means of graphical symbols

In the menus for the notation of single measurements (**Variable contour lines**, **Isometry** and **False color presentation**) the option **Autoscale** effects the usage of the entire display range for the measuring values.

Moreover, you have the possibility of switching between different image memories of series of measurements by means of the **plane selection**. Switching is also possible by means of the cursor keys up/down if the plane selection is selected. If the plane selection in the display menus is set on **Global**, switching simultaneously between the planes is possible via the selection in the tool bar.

The title of the dialogue window indicates the name of the data sets shown.

For the parallel evaluation of several measurements the program has 50 image memories which can record one measurement each. These image memories (measuring plane) can also be used in order to record changed measurement values in case of a parameter variation.

Due to the variation of the z-position in the different planes a caustic measurement is realized. Due to a change of the laser power it is possible to simulate, e.g. the thermal inflow-behavior of the system. Similarly, time series are possible. Respective displays are, for instance, possible by means of the menu item **Graphical review**.

10.2.1 False colors

Here, a false color presentation of the measured power density distribution is generated.

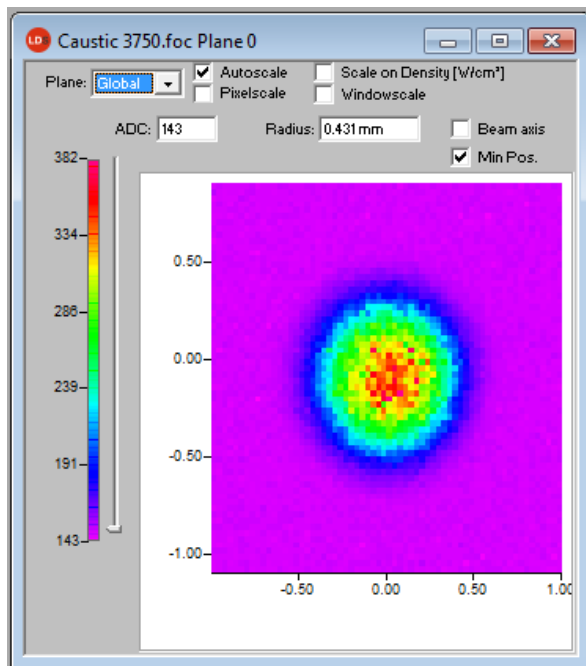

Fig. 10.11: Dialogue window **False colors**

The used color scale is shown on the left. For a higher sensitivity, e.g. for the analysis of diffraction figures, it is possible to switch the used color scale in the menu **Presentation>>Color Tables**.

By means of the slide control on the right hand side of the color scale you can display the sections of different ADC values with the corresponding radii.

Apart from the automatic scaling, there are three more types of scaling.

Scale on density

All planes of a caustic measurement are scaled on the maximum measured power density. This is supposed to help comparing the different planes more easily.

Pixel scale

This scaling is only interesting when it comes to the usage of asymmetric measuring windows. In this case the axis of the windows are no longer a function of the measuring window size but of the number of pixels measured.

Window scale

With regard to this function, all measuring windows of a caustic measurement are enlarged to the size of the maximum measuring window. This function, too, is supposed to help comparing the different measuring planes of a caustic measurement more easily.

Beam axis

The beam axes can be displayed.

10.2.2 False colors (filtered)

The special function of the filter is called spline – function. It is characterized by the fact that the position of the maximum is maintained. The single pixels in the matrix are weighed by means of a 1-2-1 filter in order to reduce the noise.

This filter can also be used multiple times without the position of the maxima being moved.

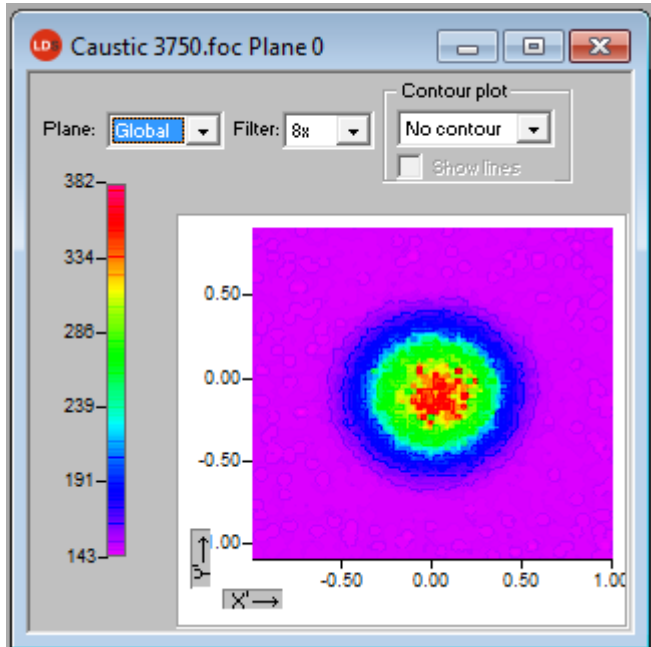

Fig. 10.12: Dialogue window False colors (filtered)

10.2.3 Isometry

This menu item generates a spatial display of the measured power density distribution of a plane. The false color display can be deactivated.

A turn of the distribution by 0°, 90°, 180° and 270° each is possible.

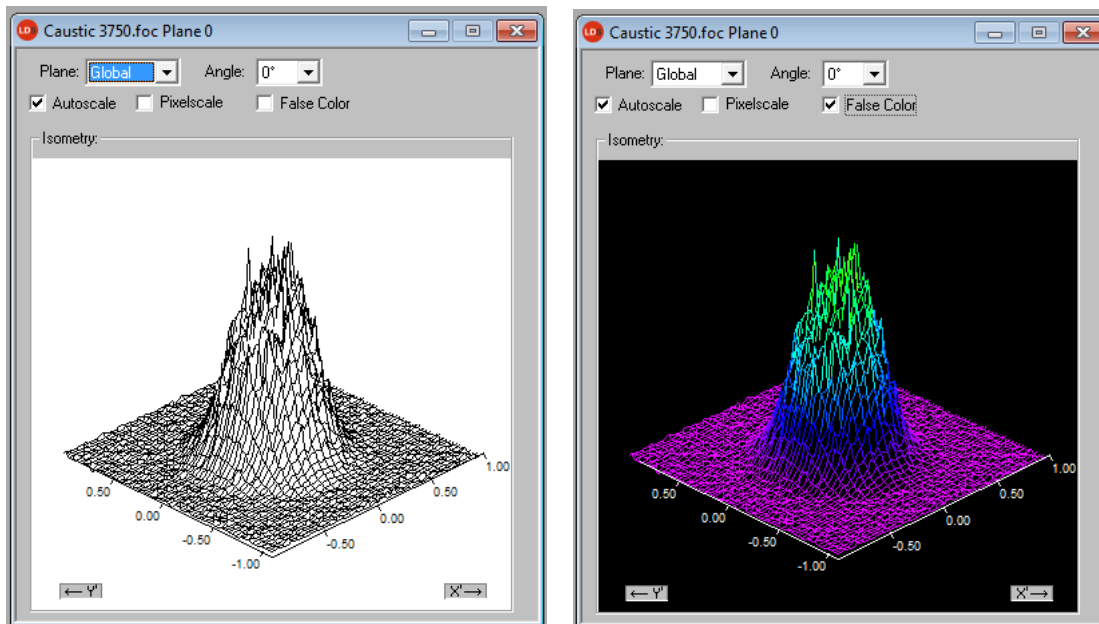

Fig. 10.13: Dialogue window Presentation>>Isometry (on the left with a deactivated color display)

10.2.4 Caustic display (2D-display)

The results of the caustic measurement can be displayed by means of the menu item **Presentation>>Caustic**. On the left Fig. 10.14 shows the measured beam parameter either on the basis of the 86%-radii or the moment evaluation according to ISO 11146. In the middle of the picture the graphic shows the caustic profile. The beam radii are depicted on the beam spread direction. On the right the false color presentation of one measurement plane each – among other things selectable with the mouse - is shown together with numerical results of this single plane.

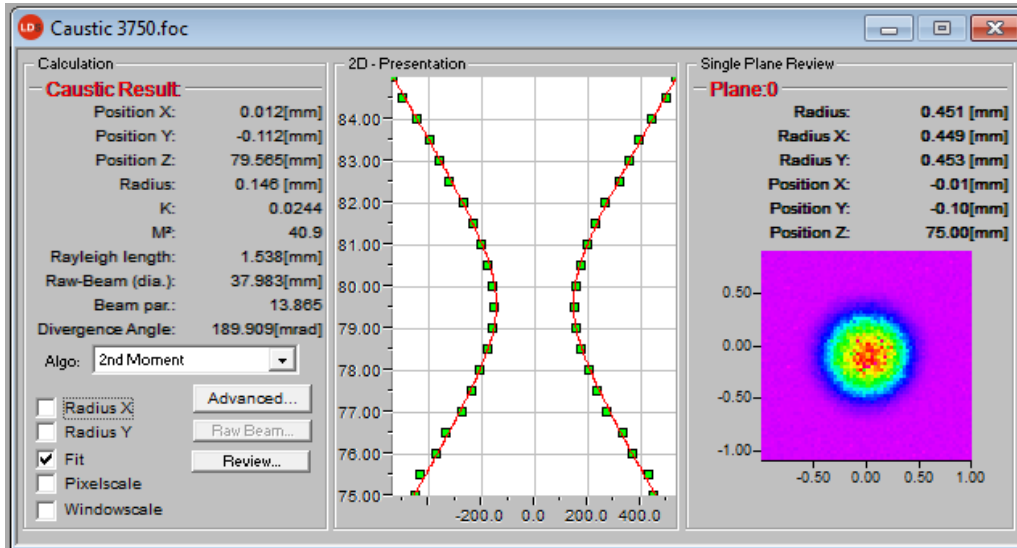

Fig. 10.14: Dialogue window **Presentation>>Caustic**

The red line depicts a compensating curve according to the calculated fits which can be displayed via the check box **Fit** in the 2D presentation

Compensating curve

In order to evaluate the caustic, a hyperbolic compensating curve (ISO 11146) is adapted to the measuring values. This compensating curve describes the propagation of an ideal laser beam mathematically. The development of the compensating curve is theoretically determined by means of the following parameters.

- standardized beam quality factor M^2 or respectively beam propagation ratio
- z-position
- focus radius
- rayleigh length

Standardized beam quality factor M^2 (or respectively the beam propagation ratio $K = \frac{1}{M^2}$)

The standardized beam propagation ratio describes how well the respective laser beam can be focused in relation to the single mode. The single mode is the best beam which is theoretically possible and has a beam quality factor of 1. All other beams have higher values. For welding lasers (CO_2) the values range from 2 to 5. With regard to cutting lasers (CO_2) values from 1.1 to 2.5 are common. In case of beam sources with a higher laser power the beam quality factors are generally smaller than those of sources with lower laser powers.

Z-Position

This value provides the position of the focus points in the z-position. As the compensation curve takes the measurement points into consideration, the calculated z-position is not necessarily located at the beam radius, which has measured the smallest position.

The device coordinates are given. Information with regard to the absolute position in space can be found in chapter 22 on page 95. Possibly also on basis of a TCP calibration (option).

Focus radius

The focus radius is the smallest beam radius in the caustic. Generally, this value is similar to the smallest value measured.

Due to different reasons it may occur that the adaption to the measurement values was not carried out. This is the case if the compensation curve does not lie close to the measurement values. In this case the parameters of the adapted compensation curve are to be discarded.

The evaluation function (please see page 18) provides more information on this topic.

Rayleigh length

The Rayleigh-length is a derived parameter and describes the distance in z-direction with regard to which the beam radius has increased by the factor $\sqrt{2}$ (=1.41) and concerning which the beam area has increased by the factor 2. The Rayleigh-length increases with the beam propagation ratio and the focal width of the focusing optic (please see chapter 22 on page 95). The doubled Rayleigh length is an approximate point of reference, up to which material thickness (metal) a procession is possible with the optic employed.

In order to make sure that the adapted values have a high significance, the measurement is to be carried out in a z-range of at least two Rayleigh-lengths. A range of four Rayleigh-lengths – as demanded in the ISO 11146 would be even better. 5 to 6 Rayleigh-lengths would be ideal. However, this demand is often confronted with the problem of quickly sinking power densities of the laser beam which is to be measured. In case of a distance of two Rayleigh-lengths from the focus the power density has sunk to just a quarter.

In this case the caustic measurement consists of a compromise between the desired measurement range in z-direction and the power density (signal-to-noise ratio) necessary for a perfect measurement.



Fig. 10.15: Result window **Caustic>>Advanced**

For the examination of asymmetric beams the dimensions of the main axes of the beam can be determined. On the basis of these values the program also calculates direction dependent beam quality factors as well as beam position values. The related curves are shown via the two check boxes radius x, y while the numerical values are provided by the detail menu.

Review

This function checks whether the results and settings of the caustic measurement are within the reliable range.

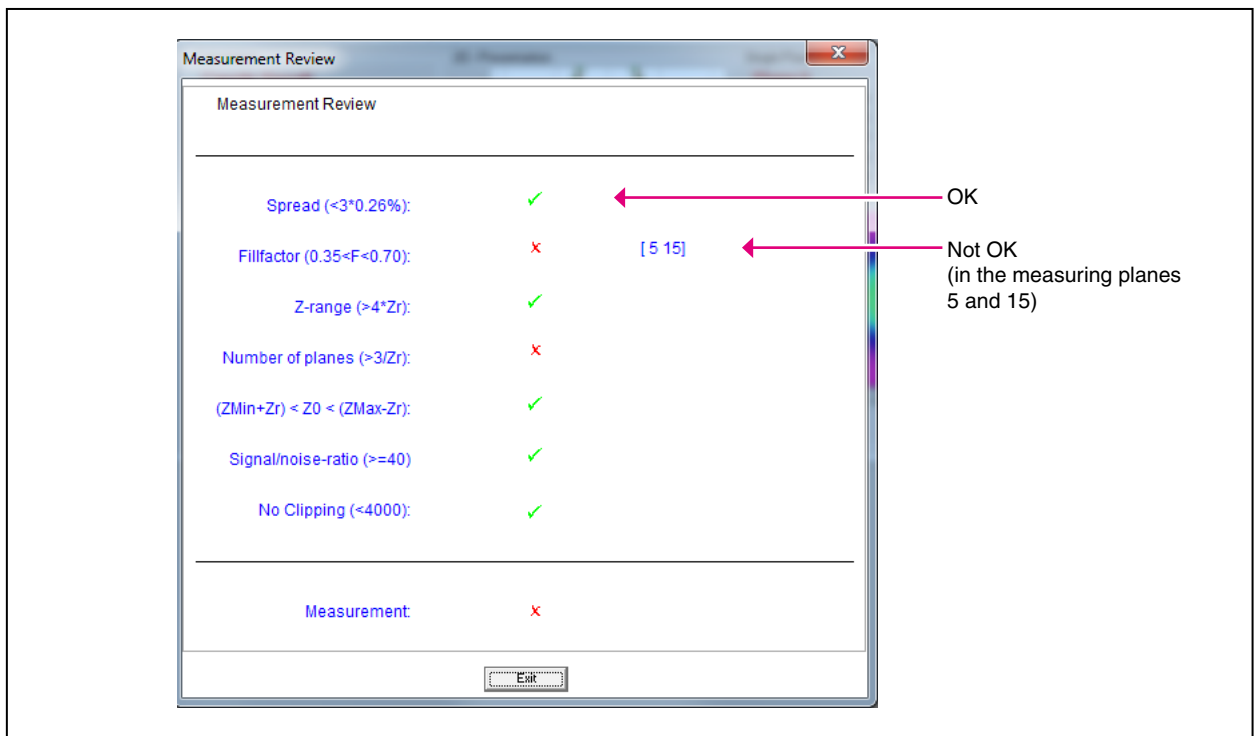

Fig. 10.16: Result window of the evaluation function

Under “spread” the average standard deviation of the caustic fit according to the 2nd moment method radii is stated. A “tick” (✓) is set if the standard deviation is smaller than 3.5 % and if all of the measuring values lie within a range of ± 3 * standard deviation.

Valued functions	Test criterion	Positive evaluation ✓
Spread	Average relative standard deviation of the caustic fit according to the 2nd moment method	Standard deviation < 3.5 %, all measurement values within a range of ± 3 * standard deviation
Fill factor	The proportion beam diameter to the measuring window size	In the range 0.3 – 0.7
Z-range	Measuring range in z-direction	At least 4 Rayleigh-lengths
Measurement planes	Number of measurement planes per Rayleigh length	At least 3 measurement planes per Rayleigh length
$(Z_{Min} + Z_r) < Z_0 < (Z_{Max} - Z_r)$	Minimum measurement range above and below the focusing plane	The focus lies within the minimum measurement range and this range accounts for at least one Rayleigh length in every z-direction
Signal/noise ratio	Examines the signal-to-noise ratio	FocusMonitor: S/N > 40
Signal override	Examines the maximum power density value	Below 4000 Counts

Tab. 10.2: Criteria for the evaluation

If all criteria are fulfilled, the measuring results have a high reliability. The absolute accuracy can not be stated from the standard deviation from the fits as all the systematic measuring errors as well as the accuracy of the calibration are additionally taken into account when it comes to the absolute error.

As far as the FocusMonitor is concerned different detectors can be used. Therefore, not the amplitude but the signal-to-noise ratio (S/N ratio) is evaluated as different detectors can have a different noise. For the evaluation the detector set in the menu **Measurement>>Sensor parameter** is used. In case the S/N ratio lies above 40:1 a green tick (✓) is displayed. A red cross (✗) indicates a S/N ratio lower than 25:1; in this case noise components can increase the measurement inaccuracy for the beam diameter as well as derived sizes. In case only the last, outermost plane of a caustic shows a bad signal-to-noise ratio, it is often still possible to receive strong results. If several planes are affected, a measuring tip – detector combination which is accurately adapted to the application can lead to a higher signal-to-noise ratio.

10.2.5 Isometry 3D

This function generates three-dimensional displays of the power density distribution of a plane and all planes in false colors.

The presentation window is divided. On the left the caustic, on the right the power density distribution in a plane is displayed. The horizontal size of the single windows can be changed by drawing the separating bar by means of your mouse.

The graphics can be rotated along all three axes with the left mouse button, with the right mouse button they can be positioned in the window.

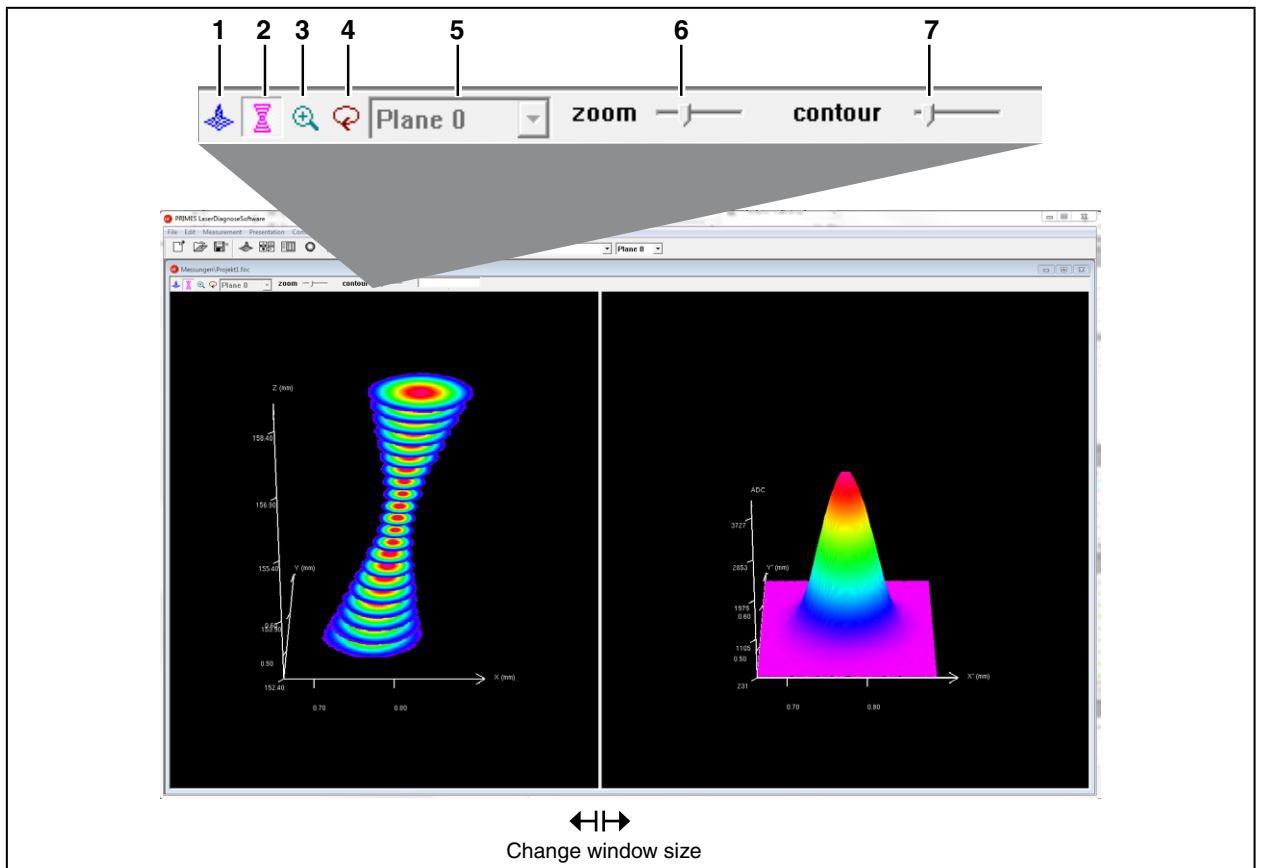

Fig. 10.17: Presentation in 3D

1	3D presentation of the plane	Inserts the 3D presentation of the power density distribution in the plane in the display window.
2	3D presentation of the caustic	Additionally inserts the 3D presentation of the caustic in the presentation window.
3	Magnification in the plane	In the left part of the presentation window a magnification of the plane displayed on the right is inserted (the desired area can be clicked by means of the left mouse button in the right window).
4	Rotation	Causes a rotation of both graphics along the z-axis.
5	Plane selection	Here the plane, which is to be displayed, can be chosen (you can also choose the desired plane in the 3D caustic by means of the left mouse button).
6	Zoom	Slide control for a continuous magnification of the presentation
7	Contour	Slide control for a contour trimming along the power density.

10.2.6 Review 86 % or 2nd Moment

For the radius definition there are two basic determination possibilities:

- Determination of the beam radii according to the 86% - power definition (chapter 22.2.4 on page 100)
- Determination of the beam radii according to the 2nd moment method (ISO 11146), (chapter 22.2.3 on page 99)

Further possibilities are provided additionally by the software (please see chapter 22.2.5 on page 101).

Plane:	Plane 0	Plane 1	Plane 2	Plane 3	Plane 4	Plane 5	Plane 6	Plane 7	Plane 8	Plane 9	Plane 10	Plane 11	Plane 12	Plane 13
Radius [mm]	0.431	0.398	0.362	0.313	0.289	0.233	0.201	0.169	0.146	0.138	0.148	0.171	0.197	0.231
Position X [mm]	-0.010	-0.023	0.007	0.002	0.005	0.010	0.018	0.008	0.017	0.012	0.015	0.020	0.023	0.028
Position Y [mm]	-0.108	-0.109	-0.098	-0.102	-0.100	-0.104	-0.108	-0.108	-0.111	-0.112	-0.111	-0.110	-0.110	-0.110
Position Z [mm]	75.000	75.000	76.000	76.500	77.000	77.500	78.000	78.500	79.000	79.000	80.000	80.500	81.000	81.500
Zero level [A/D-Cnts]	149.750	149.800	149.250	149.250	149.750	149.750	149.750	150.000	149.500	150.000	149.750	149.500	149.750	149.750
Power [W]	0.900	0.900	0.900	0.900	0.900	0.900	0.900	0.900	0.900	0.900	0.900	0.900	0.900	0.900
Radius Inten. [kW/cm²]	47.404	51.499	65.531	82.451	119.463	156.968	217.734	346.400	644.733	1031.441	643.356	338.405	242.709	171.356
Peak Inten. [kW/cm²]	280.498	435.540	547.987	586.358	769.836	1077.156	1451.039	1640.708	1806.861	1832.281	1815.033	1906.408	1683.383	1084.000
Date:	20.12.2010	20.12.2010	20.12.2010	20.12.2010	20.12.2010	20.12.2010	20.12.2010	20.12.2010	20.12.2010	20.12.2010	20.12.2010	20.12.2010	20.12.2010	20.12.2010
Time:	14:54:26	14:54:34	14:54:48	14:54:56	14:55:10	14:55:18	14:55:25	14:55:33	14:55:40	14:55:48	14:55:55	14:56:03	14:56:10	14:56:17
Focal length [mm]	200.000	200.000	200.000	200.000	200.000	200.000	200.000	200.000	200.000	200.000	200.000	200.000	200.000	200.000
Z-axis-offset	0.000	0.000	0.000	0.000	0.000	0.000	0.000	0.000	0.000	0.000	0.000	0.000	0.000	0.000
X-axis-offset	0.000	0.000	0.000	0.000	0.000	0.000	0.000	0.000	0.000	0.000	0.000	0.000	0.000	0.000
Y-axis-offset	0.000	0.000	0.000	0.000	0.000	0.000	0.000	0.000	0.000	0.000	0.000	0.000	0.000	0.000
Coord.rotation [deg.]	0.000	0.000	0.000	0.000	0.000	0.000	0.000	0.000	0.000	0.000	0.000	0.000	0.000	0.000
Wavelength [µm]	1.064	1.064	1.064	1.064	1.064	1.064	1.064	1.064	1.064	1.064	1.064	1.064	1.064	1.064
Fill Factor	0.431	0.398	0.470	0.418	0.538	0.467	0.401	0.451	0.381	0.389	0.398	0.455	0.527	0.462

Fig. 10.18: Result window Presentation>>Review (86%)

Plane:	Plane 0	Plane 1	Plane 2	Plane 3	Plane 4	Plane 5	Plane 6	Plane 7	Plane 8	Plane 9	Plane 10	Plane 11	Plane 12	Plane 13
Radius [mm]	0.451	0.430	0.388	0.332	0.272	0.237	0.205	0.175	0.158	0.149	0.156	0.174	0.199	0.234
Radius X [mm]	0.449	0.428	0.389	0.331	0.273	0.237	0.204	0.176	0.159	0.151	0.158	0.176	0.199	0.231
Radius Y [mm]	0.453	0.432	0.387	0.332	0.272	0.238	0.207	0.174	0.158	0.147	0.155	0.171	0.198	0.238
Angle [°] (WvPlane)	-20.8	-10.1	33.6	17.1	37.2	28.2	38.0	2.8	32.8	10.0	25.1	39.2	22.7	43.0
Position X [mm]	-0.008	-0.020	0.006	0.001	0.003	0.008	0.014	0.004	0.016	0.012	0.014	0.018	0.022	0.027
Position Y [mm]	-0.103	-0.113	-0.098	-0.104	-0.104	-0.105	-0.108	-0.105	-0.110	-0.110	-0.109	-0.109	-0.109	-0.112
Position Z [mm]	75.000	75.000	76.000	76.500	77.000	77.500	78.000	78.500	79.000	79.000	80.000	80.500	81.000	81.500
Zero level [A/D-Cnts]	149.750	149.800	149.250	149.250	149.750	149.750	149.750	150.000	149.500	150.000	149.750	149.500	149.750	149.750
Power [W]	0.900	0.900	0.900	0.900	0.900	0.900	0.900	0.900	0.900	0.900	0.900	0.900	0.900	0.900
Peak Inten. [kW/cm²]	280.498	435.540	547.987	586.358	769.836	1077.156	1451.039	1640.708	1806.861	1832.281	1815.033	1906.408	1683.383	1084.000
Date:	20.12.2010	20.12.2010	20.12.2010	20.12.2010	20.12.2010	20.12.2010	20.12.2010	20.12.2010	20.12.2010	20.12.2010	20.12.2010	20.12.2010	20.12.2010	20.12.2010
Time:	14:54:26	14:54:34	14:54:48	14:54:56	14:55:10	14:55:18	14:55:25	14:55:33	14:55:40	14:55:48	14:55:55	14:56:03	14:56:10	14:56:17
Focal length [mm]	200.000	200.000	200.000	200.000	200.000	200.000	200.000	200.000	200.000	200.000	200.000	200.000	200.000	200.000
Z-axis-offset	0.000	0.000	0.000	0.000	0.000	0.000	0.000	0.000	0.000	0.000	0.000	0.000	0.000	0.000
X-axis-offset	0.000	0.000	0.000	0.000	0.000	0.000	0.000	0.000	0.000	0.000	0.000	0.000	0.000	0.000
Y-axis-offset	0.000	0.000	0.000	0.000	0.000	0.000	0.000	0.000	0.000	0.000	0.000	0.000	0.000	0.000
Coord.rotation [deg.]	0.000	0.000	0.000	0.000	0.000	0.000	0.000	0.000	0.000	0.000	0.000	0.000	0.000	0.000
Wavelength [µm]	1.064	1.064	1.064	1.064	1.064	1.064	1.064	1.064	1.064	1.064	1.064	1.064	1.064	1.064
Radius X [mm]	0.449	0.428	0.389	0.331	0.272	0.237	0.205	0.175	0.159	0.151	0.157	0.174	0.199	0.234
Radius Y [mm]	0.452	0.432	0.388	0.332	0.272	0.237	0.208	0.174	0.158	0.148	0.155	0.173	0.198	0.234
Fill Factor	0.451	0.430	0.491	0.442	0.545	0.475	0.411	0.466	0.422	0.398	0.416	0.464	0.530	0.469
Ellipticity (Rmin/Rmax)	0.991	0.992	0.994	0.996	0.997	0.997	0.998	0.999	0.999	0.999	0.999	0.999	0.999	0.999
RadiusX/RadiusY	0.999	1.000	1.002	1.000	1.001	0.999	0.998	1.000	1.002	1.001	1.003	1.011	1.001	0.988
RadiusY/RadiusX	1.001	1.000	0.998	1.000	0.999	1.001	1.004	1.000	0.999	0.999	0.999	0.999	0.999	1.014
3°RadiusX/WindowSizeX	0.674	0.643	0.738	0.662	0.817	0.712	0.615	0.703	0.634	0.603	0.628	0.697	0.797	0.702
3°RadiusY/WindowSizeY	0.679	0.648	0.736	0.665	0.817	0.713	0.616	0.696	0.632	0.600	0.621	0.693	0.792	0.704

Fig. 10.19: Result window Presentation>>Sec. Moments

If the measuring signal exceeds the zero level by only a bit, the measuring results are not displayed in black but in grey. In this case it has to be checked whether the measuring values are caustic trusted or have to be deleted and if the measurement has to be repeated with other settings. The entries power, focal length and wave length, especially in the comment lines, can still be changed after a measurement. For this purpose there is the push button **Update** in the menu item **Measurement >> Environment**.

10.2.7 Symmetry Check

This display menu checks the rotational symmetry of the power density distribution of a laser beam. It can, for instance in connection with the monitor operation, be used for the alignment of laser resonators. In the following, the figures Fig. 10.21 and Fig. 10.22 show two examples for the possible results of a symmetry check at an elliptic beam.

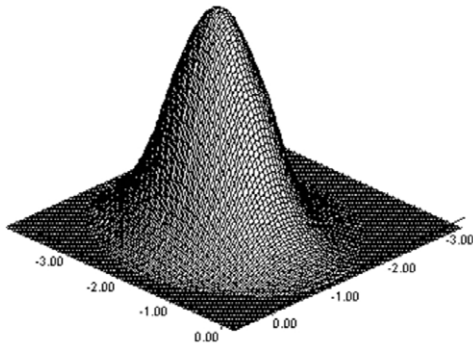

Fig. 10.20: Power density distribution of an elliptic beam

Together with the **Symmetry check** the power density distribution of an elliptic beam as displayed in Fig. 10.20 comes to the following results:

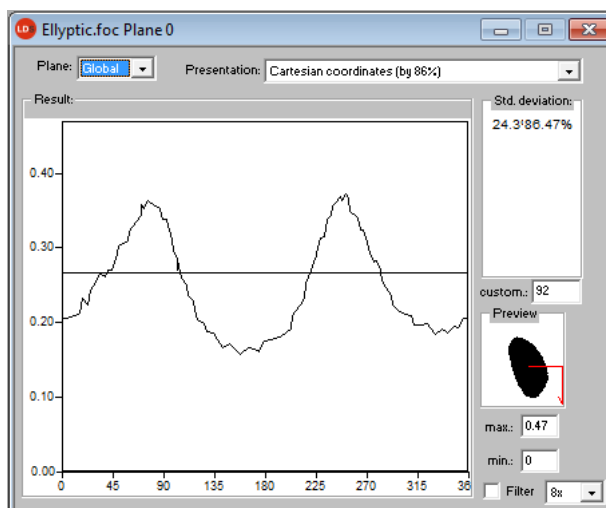

Fig. 10.21: Presentation in Cartesian coordinates

The abscissa in Fig. 10.21 shows the angle and the ordinate of the beam radius with the intersection lines at different powers between 86 % and 10 % of the total power.

On the screen the curves appear in different colors. The radius is indicated in pixel coordinates. The minimum as well as the maximum of the radius values can be chosen. On the right side the standard deviation of the different radius values is indicated. These values give detailed information on the symmetry of the beam distribution.

Well aligned resonators reach standard deviations in the range of 3 % to 5 %. Partially, values in a 1 % and 2 % range are possible.

A presentation in polar coordinates is also possible (Fig. 10.22). The drawn in lines contain 86 % up to 10 % of the detected power. On the screen the graphs have different colors. X- and y-axis scale in pixel values.

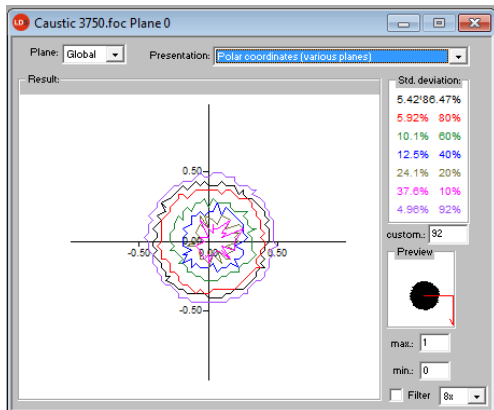

Fig. 10.22: Symmetry check in polar coordinates

10.2.8 Fixed Contour Lines

The contour lines are displayed with different power levels. Intersection lines are selected with: 86 %, 80 %, 60 %, 40 %, 20 % and 10 % of the total power.

In this presentation it is also possible to measure distances by clicking the start and end points with the mouse.

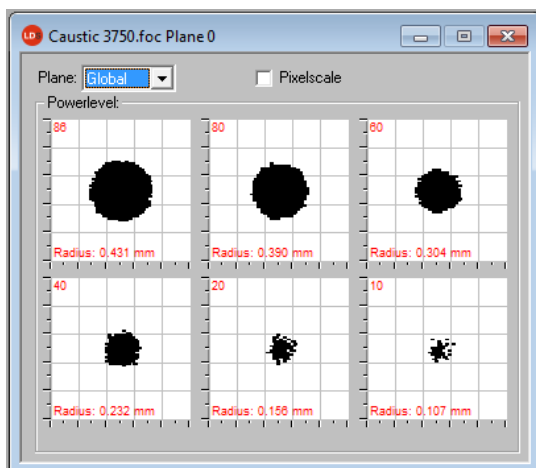

Fig. 10.23: Display window Fixed contour lines

10.2.9 Variable Contour Lines

Here the spatial power density distribution is displayed by means of freely selectable contour lines. Not only intersections in x- and y- direction but also in power density coordinates (A/D-converter-counts) can be carried out. The position of the intersections is settable by means of a slide control or the keyboard.

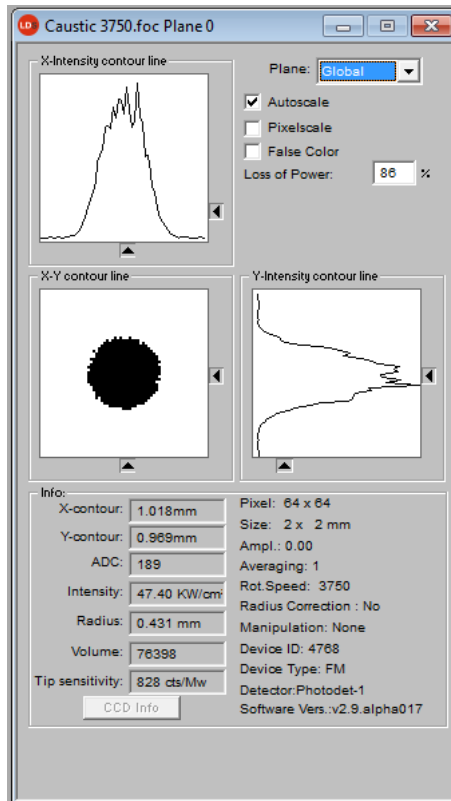

Fig. 10.24: Display window **Variable contour lines**

Setting by means of the keyboard:

- For the x-direction by means of the key **x** in order to increase the value and **<shift> x** in order to decrease it.
- For the y-direction by means of the key **y** in order to increase the value and **<shift> y** in order to decrease it.
- For the power density (intensity) by means of the key **i** in order to increase the value and **<shift> i** in order to decrease it.

In the range of the left hand lower corner the current intersection coordinates, the power densities, the radius generated by the intersection as well as the relative volume are displayed. In the lowest line the measuring tip sensitivity is displayed. The values are calculated basing on the correctly entered laser power.

In the right hand upper corner it is possible to switch to the scaling mentioned in chapter 10.2.1. Below it, there is an input field where the desired power loss (-inclusion) can be entered.

Beside these functions this window offers many more information regarding the conditions under which the measurements were carried out.

Moreover, the amplification, the number of average determinations as well as the revolution speed is displayed.

10.2.10 Graphical Review

The display window **Graphical review** offers many possibilities to display the measurement values of the single measurement planes.

Above the x-axis the power, time and planes or the z-position can be applied. For the y-axis the radius data, the x or, respectively, y-position, the angle and the ellipticity are available. In total this window can present 16 different graphs.

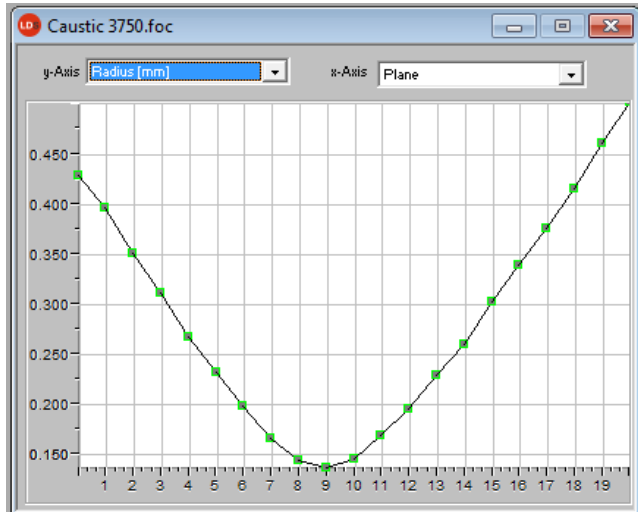

Fig. 10.25: Graphical review - example radius versus plane

10.2.11 Color Tables

Different color charts are available. It is possible to switch back and forth between the color charts. Thus the assignment of A/D converter values and different color scales can be varied. This is important for the false color presentation.

Three settings are possible:

- Linear color table (basic setting)
- Color table analogue to the root function
- Color table analogue to the fourth root function

These functions can especially be helpful as far as the analysis of slight variations near the zero level are concerned; e.g. the analysis of diffraction phenomena.

10.2.12 Position

Here, the mechanical positioning of the measuring head is described:

- to the park position (Park position $z=0$, $y=0$)
- to the measured focusing plane (Focus Position)
- to a user-defined z-position (General Z-Position)
- to a user-defined y-position (General Y-Position)

In case of a standard installation, you can choose either the carriage (selection **upper side of carrier**) or the measuring tip (selection **pin hole**) as a reference for the distances. This may be selected in the drop down listbox **Mode**. In case your device is mounted overhead, you have to activate the check box **Upside down**. Then the distances are referenced to the measuring tip or the carriage bottom edge (cover on the bottom side).

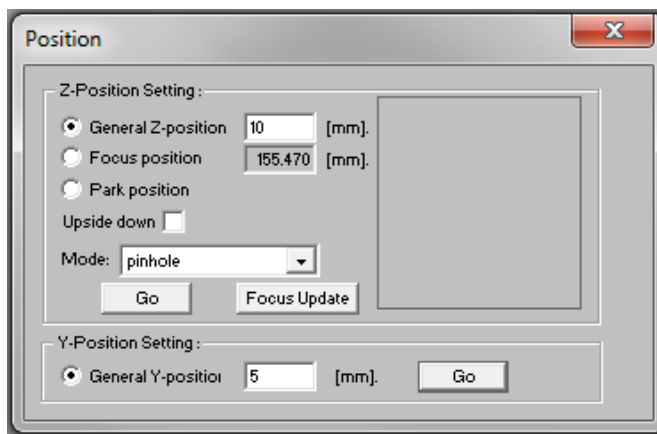

Fig. 10.26: Dialogue window **Presentation>>Position**

10.2.13 Evaluation ****OPTION****

By means of this evaluation function, you can compare and evaluate different parameters of the measured caustic (.foc-file) with specified limit values (.pro-file). The evaluation result is displayed optically with an LED symbol (red=bad, green=good). The overall result (field **Conclusion**) is only considered as good provided that all results are within the critical parameters (★).

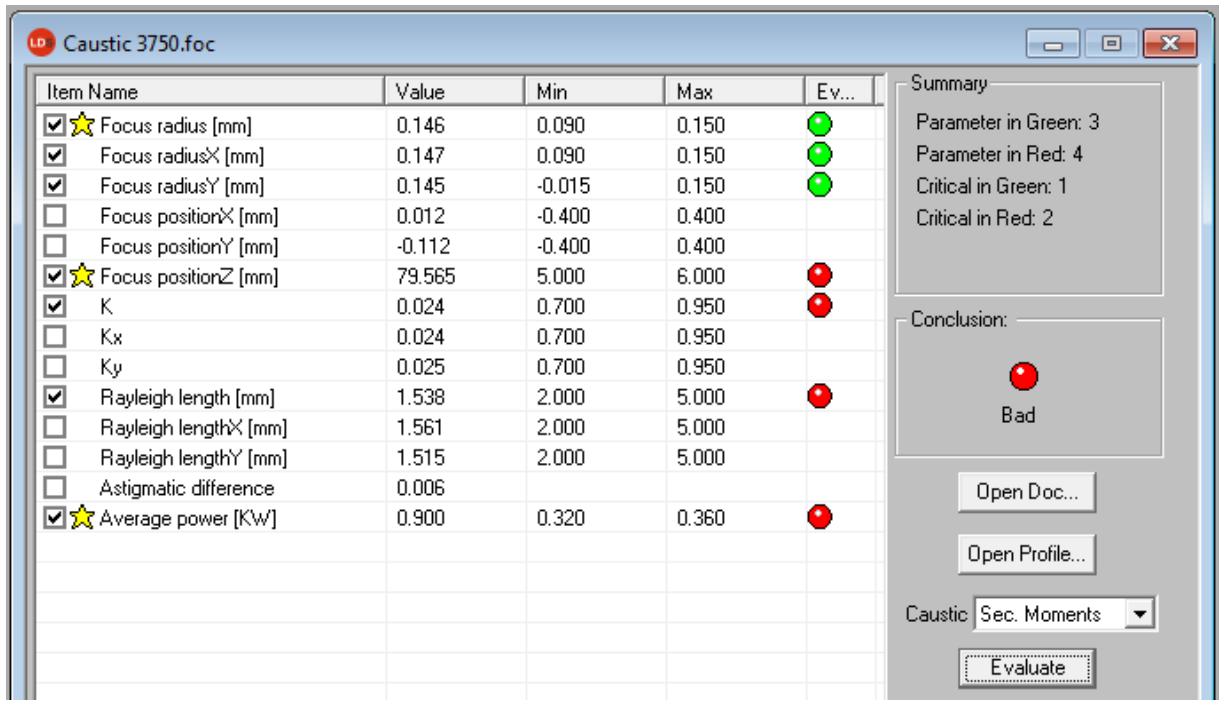

Fig. 10.27: Dialogue window Evaluation

The parameters, the limit values and the identification of critical values are purported in a profile file (text file, please see the example file in Fig. 10.28).

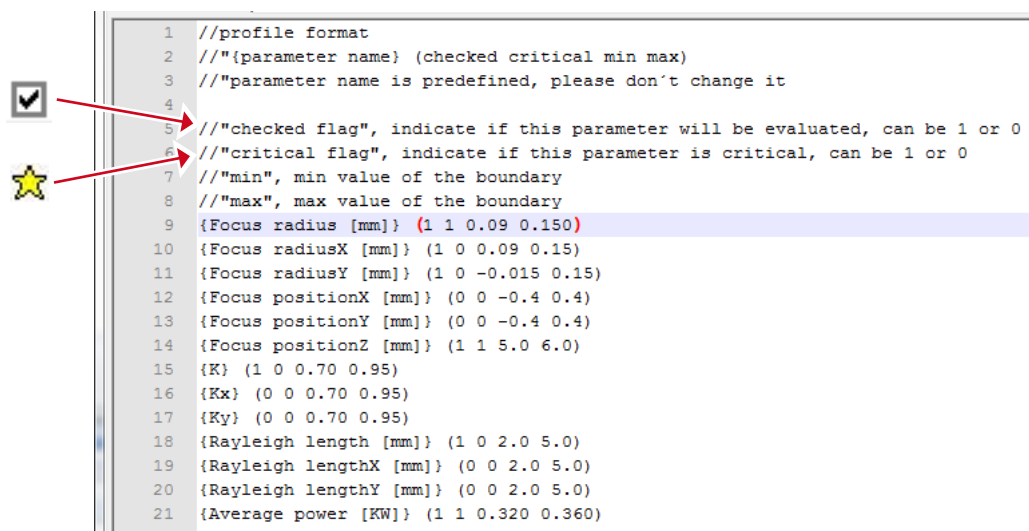

Fig. 10.28: Example for a profile file

An evaluation is carried out as follows:

1. Click the button **Open Doc...** and choose your measuring file (.foc-file).
2. Click the button **Open Profile...** and choose your profile file (.pro-file).
3. Choose the desired radius definition in the selection **Caustic**.
4. Click on the button **Evaluate**.

10.3 File

This menu includes – among others – the administration of measurement and setting data.

10.3.1 New

By means of **New** a new file is created.

10.3.2 Open

By means of **Open** a selected file is opened.

10.3.3 Save

The file currently opened is stored. The standard type of file is a binary file format with a minimal memory requirements. The file ending for a measuring file of this type is “.foc”. As an alternative, it is possible to store the data in a ASCII format with the extension “.mdf”. Information regarding the file format “.mdf” can be found enclosed. Only files with this formats can be opened by the program (see also chapter 21.2 on page 93).

10.3.4 Save As...

You have to assign a file name, choose the storage location and the file format.



Only save the measurement data with the extensions “.foc” or “.mdf”. You can only view measurement data if the respective file was explicitly selected in the tool bar.

10.3.5 Export

Exports the pixel information of the power density distribution to a Excel table (*.xls). As an alternative, the numeric results from a “.foc” file can be stored in a tab-separated text file (*.pkl) which can be imported into Microsoft Excel.

10.3.6 Load measurement preferences

Stored settings can be resorted to with **Load measurement preferences**. The standardized extension for a setting file of the FocusMonitor is “.ptx”.

10.3.7 Save measurement preferences

The current measurement settings are stored (.ptx-file).

10.3.8 Protocol

The calculated measurement results from a single plane can directly be written into a text file. The following is stored:

- Date and time of the measurement
- Beam position and beam radius (according to 86 %- and 2nd moment definition)

Therefore please activate the check box **Write**. Then you can directly enter the name in the field **File name** or you can use the standard selection menu with the button **Select**.

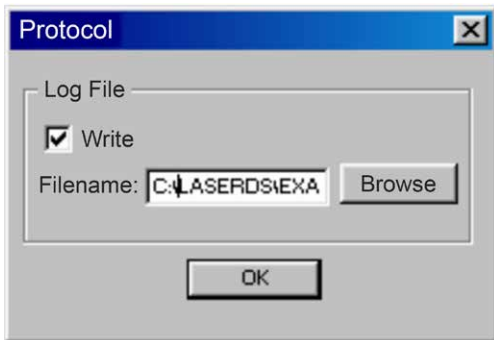

10.3.9 Print

You can print directly from the program. The current window can be printed with the menu point **Print** in the menu **File**. With the menu point **Settings** it is also possible to change the settings as far as the formats etc. are concerned.

10.3.10 Print preview...

Shows a preview of your printing order.

10.3.11 Recently opened files

Selection of the files processed before.

10.3.12 Exit

Terminates the program.

10.4 Edit

10.4.1 Copy

By means of the copy function a direct export of graphics to other programs is possible. In this case the content of the current window is transmitted to the Windows clipboard.

10.4.2 Clear plane

The content of the actual displayed measurement plane of the measurement data set selected in the tool bar is deleted.

10.4.3 Clear all planes

The content of all measurement planes of the measurement data set selected in the tool bar is deleted.

10.5 Communication

10.5.1 Free Communication

By means of this menu you can control the communication via the PRIMES bus. Moreover, the settings for the communication are made here. Further information can be found in chapter „9.4.1 Establishing a connection to PC“ on page 33.

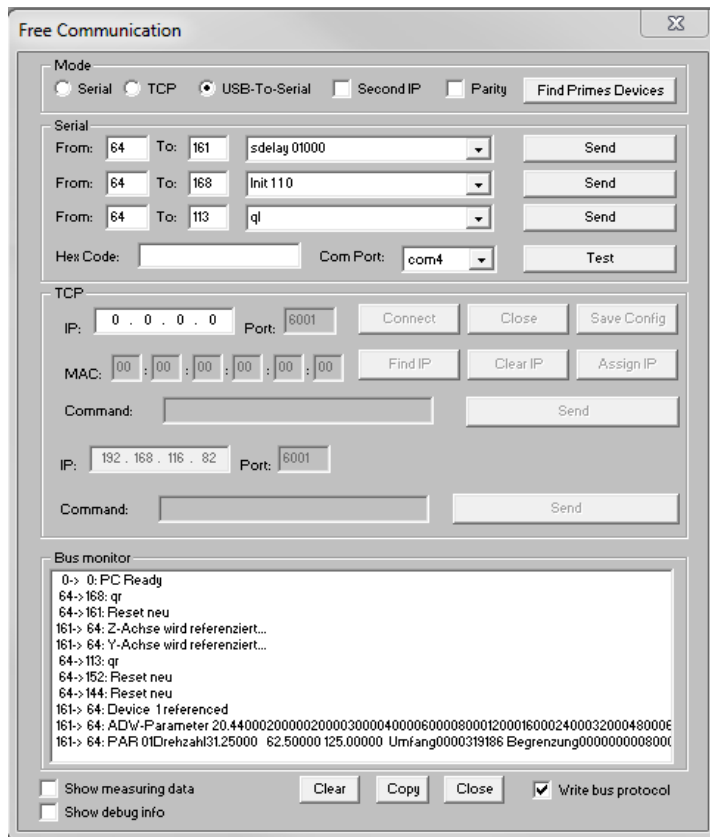

Fig. 10.29: Dialogue window **Communication>>Free Communication**



10.5.2 Scan device list

Every PRIMES device has a certain bus address. If a device is supposed to be controlled by means of the LaserDiagnosticsSoftware, the address has to be entered here. Moreover addresses can also be added or deleted in this menu

10.6 Script

By means of scripts complex measurement procedures can be controlled automatically. Scripts are programs which are written in several script languages. Scripts are almost exclusively provided as source files in order to enable an easy editing and adjustment of the program.

10.6.1 Editor

By means of the script editor you can draw up scripts which can control, for example, complex measuring procedures automatically. An example is given in Fig. 10.30 – the beam find procedure with the BeamMonitor. In order to open the script, the Open symbol has to be clicked, then a file can be chosen and played by using the button . The button  stops and  ends the script.

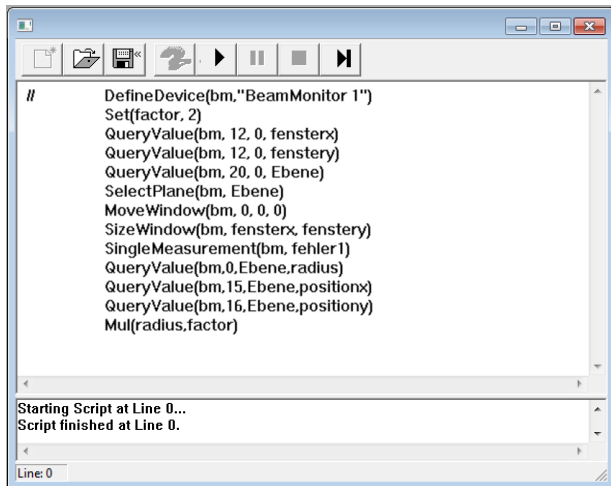

Fig. 10.30: Script for the beam find procedure of the BeamMonitor

10.6.2 List

Here all available scripts are listed

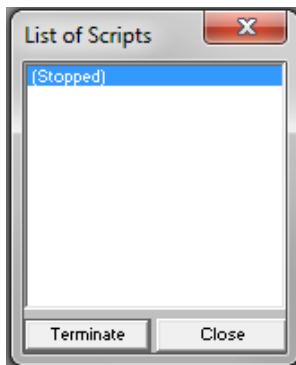

Fig. 10.31: List of the available scripts

10.6.3 Python

Starts the Python editor. The graphical user interface is identical to the one depicted in Fig. 10.30. Python is a programming language with efficient abstract data structures and a simple but effective approach for an object-oriented programming. Python is not only suitable for scripts but also for a fast application development. For detailed information about the script control, see the separate description “Documentation for the Python Script Control of the PRIMES LaserDiagnosticsSoftware”.

11 Measuring

This chapter describes the manual control of the PRIMES laser diagnostics system.

An automatic measurement with the FocusMonitor can be started via the PRIMES-PLC-interface of the system control. In this case, the system control deals with the entire measuring operation e.g. via a script. The work with the script control is explained in the corresponding documentation.

DANGER

Danger of injuries due to laser radiation

Scattered radiation is developed during the measurement.

- ▶ **Please always wear laser safety goggles (OD 6) which are adapted to the laser wavelength used and appropriate safety clothing.**
 - ▶ **Please ensure an adequate shielding of the scattered radiation and the complete absorption of the radiation passing the device.**
 - ▶ **Please ensure a vertical beam incidence into the measuring device.**
 - ▶ **In operation, keep a safety distance of 1 meter to the FocusMonitor!**
-

11.1 Special safety instructions

CAUTION

There is a danger of injuries due to rotating parts

The measuring tip of the FocusMonitor is rotating at high speed during the measuring operation.

- ▶ **Do not reach into the beam entrance of the measuring device, neither with your hand nor with any items (see Fig. 11.1). Even after end of measurement the tip rotate for a while.**
-

CAUTION

There is a danger of crushing in case of the FocusMonitor

Unlike the housing, the measuring head of the FocusMonitor is movable in the z- and y-axis.

- ▶ **Do not reach into the movement range of the measuring head (see Fig. 11.2).**
-



Fig. 11.1: Danger due to rotating parts

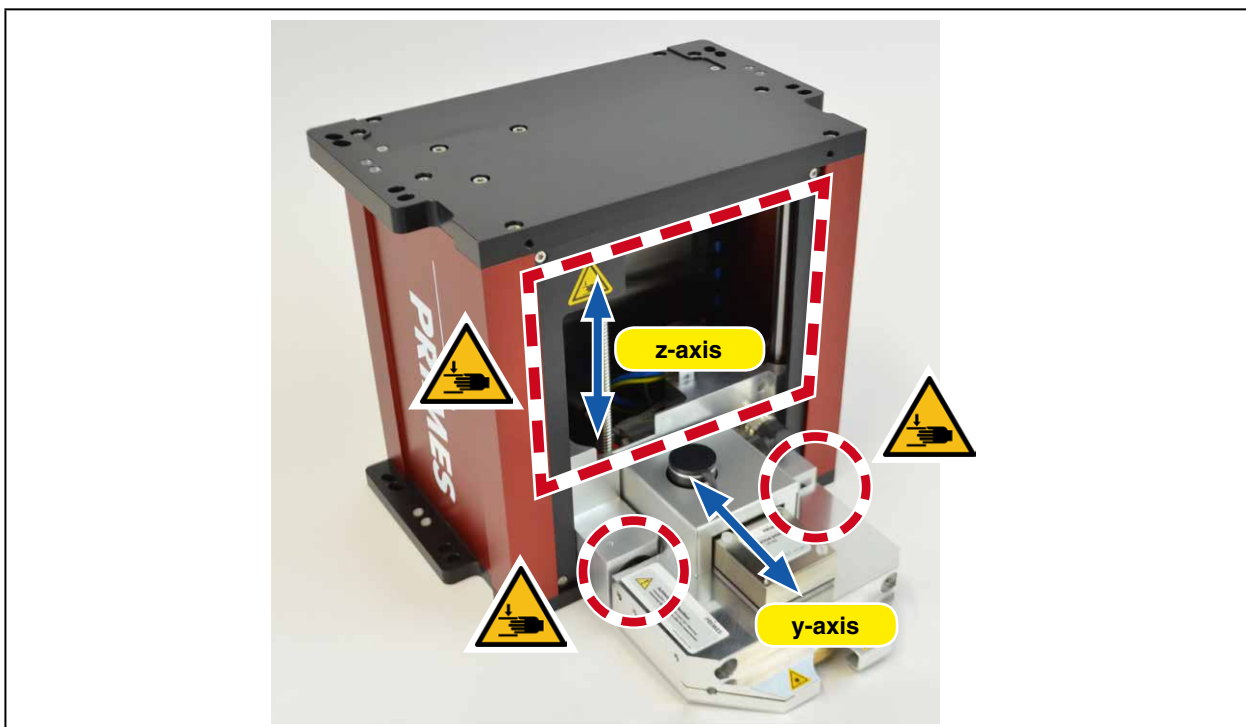

Fig. 11.2: Crushing hazard at the FocusMonitor

The device bears the following pictogram to indicate possible dangers (see Fig. 11.2



11.2 Requirements

The following description takes as granted that

- the safety measures stipulated in chapter „1 Basic safety instructions“ were obeyed
- the measuring devices were aligned and mounted correctly and solidly according to chapter „5 Installation“
- all components of the measuring system are connected according to chapter „6 Electrical connections“
- the software (LDS) is installed according to chapter „9.2 Installing the software“.

11.3 Possible Types of Measurement

11.3.1 Single Measurement

Only one measurement in one plane is carried out. The single measurement can be adjusted automatically or manually. The position and the size of the measuring window can be adjusted relatively to the maximum measurement range. The amplification is adjustable separately. A false color presentation is possible.

11.3.2 Caustic measurement

Several measurements in different planes of the z-axis are carried out. The parameters can be adjusted automatically or manually in the menu item **Measurement**, **Measurement Settings**. The measurement enables the direct determination of the beam quality factor M^2 (beam propagation ratio K).



When measuring with the DFY-PS+ Detector you have to carry out a manual single measurement before the caustic measurement can be started (please see chapter 11.5 on page 74).

11.4 Brief Instruction for a first Single Measurement



Please turn on the supply voltage of the device and wait for about 20 seconds. Then the software can be started.

When turning the supply voltage on and off a reset cycle is started within the device. During this time no measurements are possible!

1. Please turn on the supply voltage. Wait for approximately 20 seconds until the boot process is finished.
2. .Please start the LaserDiagnosticsSoftware. The connected devices are recognized within 20 seconds and in the upper right hand corner the device symbols are displayed.

Device symbols

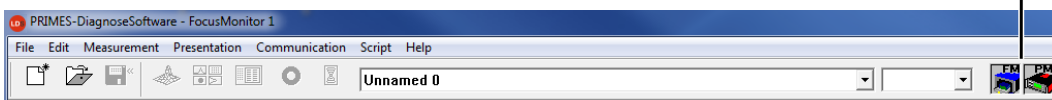

In case the device is **not** recognized:

Please open the dialogue window **Communication**>>**Free Communication** and make the following settings:

- Select the mode TCP (the option „Second IP“ must not be activated).
- Type in the IP address of the device in the field „TCP“.
- Click the button „Connect“ („Connected“ appears in the bus monitor).
- Click the button “Save” (this configuration will be stored and needs not to be typed in after restart of the software).

3. Please open the dialogue window **Measurement** >> **Environment** and enter the following:

- A The focal length
- B Select the wave length

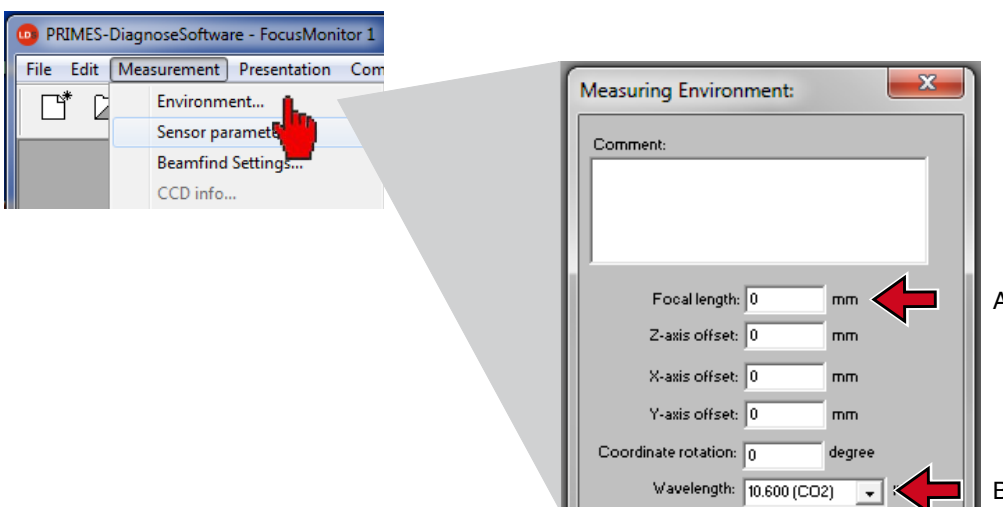

4. Please open the dialogue window **Measurement>>Sensor parameter** and choose:

- A The revolution speed (rpm), which you have determined by means of the table in chapter „14 Variety of Detectors and Measurement Tips“ on page 79 and the data sheet of the measuring tip.
- B The resolution X: 128 (recommended)
- C The resolution Y: 128 (recommended)
- D The detector type (can be found on the label of the detector).

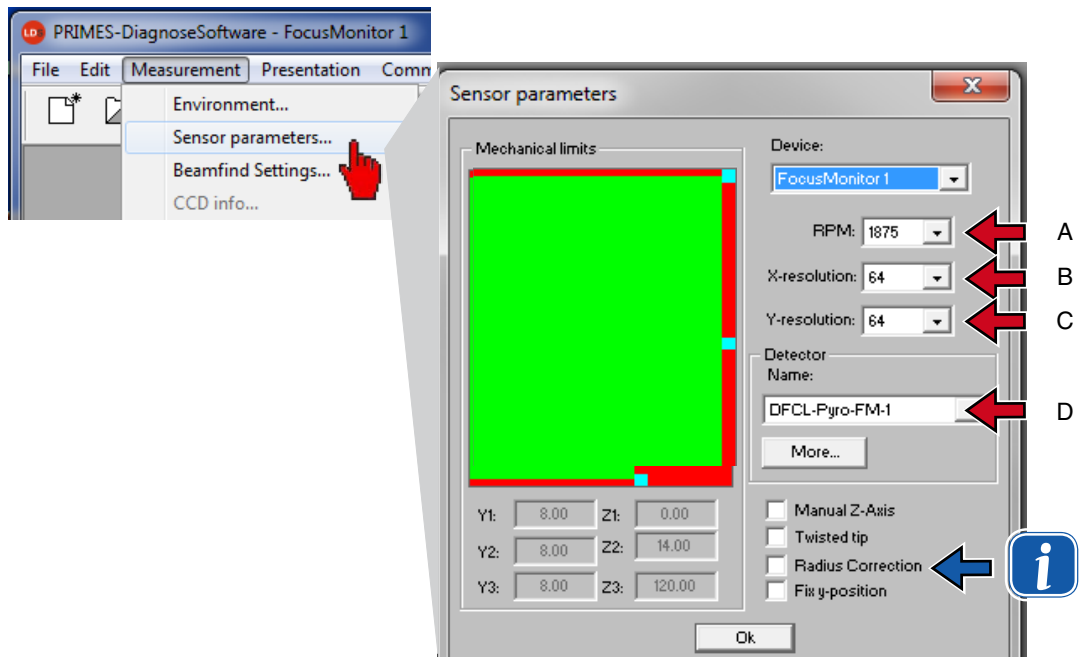

In case of rectangular or linear laser beams we recommend the activation of the radius correction.

5. Please open the dialogue window **Measurement>>Single...** and select
- A The desired z-position
 - B Window size in x-direction: recommended setting X=0.8 mm
Window size in y-direction: recommended setting Y=0.8 mm
 - C False colors

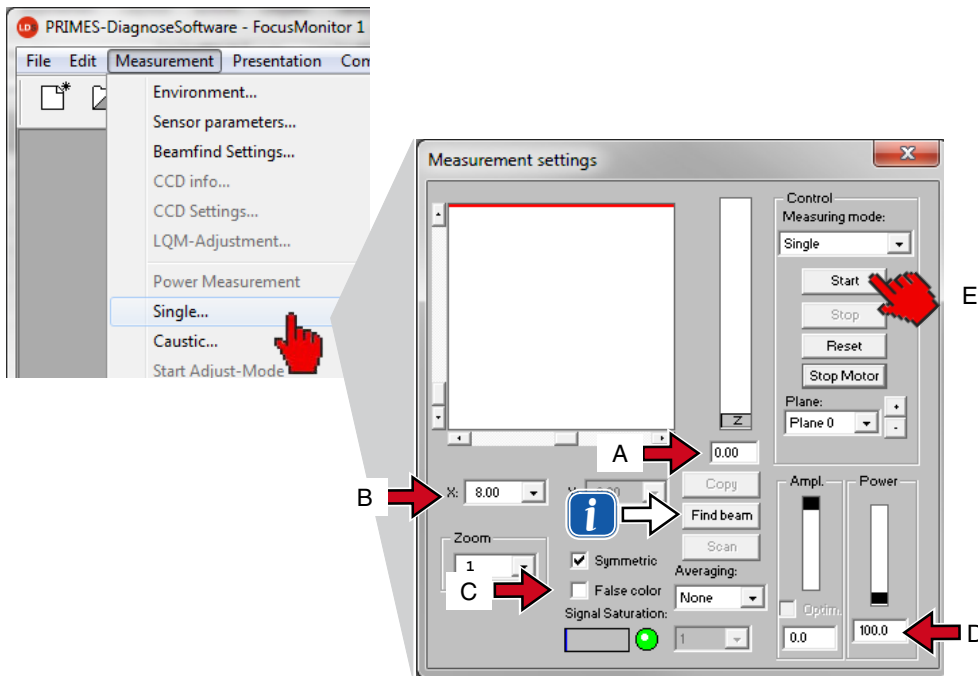

- D In the range “Power” the laser power of the beam which is to be measured has to be typed in. Please determine the power density which is to be expected and make sure that the damage threshold is not exceeded (please see Tab. 14.3 on page 81 and Tab. 14.4 on page 82).
- E Please turn on the laser and click on the “Start” button.



With regard to the FocusMonitor the button **Beam Find** automatically deals with the positioning and the selection of the measuring window. With regard to this, the z-position remains unchanged and the search is limited to the window range. In case the search was successful, the measuring window found is displayed. It is only a search function. The measuring window size is not optimized.

Signal saturation (for detectors of NIR- and CO₂-Lasers):
In case the signal is too big, the amplification can be reduced.

Detector type	Adjustable sensitivity
DFY-PS+	Yes (automatically)
DFIG-PS+	Yes (automatically)
DFCM+	No

The measuring results can be visualized by means of the menu item **Presentation>>Variable Contour Lines** (please see Fig. 11.3). Here the contour lines of the spatial power density distribution in x- and y-direction are displayed.

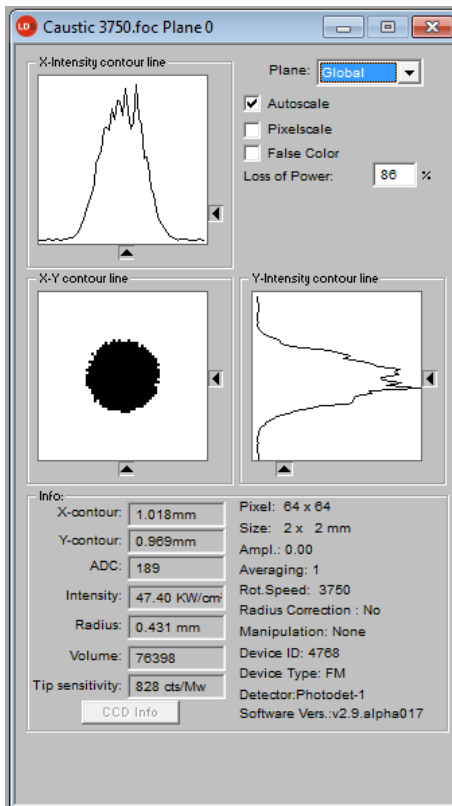

Fig. 11.3: Display of the measuring result by means of variable contour lines

In **Measurement>>Measuring Environment>>Comment** specific details regarding the beam source, the used focusing optic etc. can be entered.

In the menu item **File>>Save** the measuring data can be saved.

11.5 Measurement with a DFY-PS+/DFIG-PS+ Detector

By means of this new detector for the NIR a high dynamic range is available, even without a mechanical switch. Due to a high dynamic range it needs a manual single measurement before the caustic measurement when measuring with a DFY-PS+/DFIG-PS+ detector.

1. Please open the dialogue window **Measurement>>Single...** and choose

- A The measuring mode **Single**
- B The **Plane 0**
- C The window size in x- and y- direction

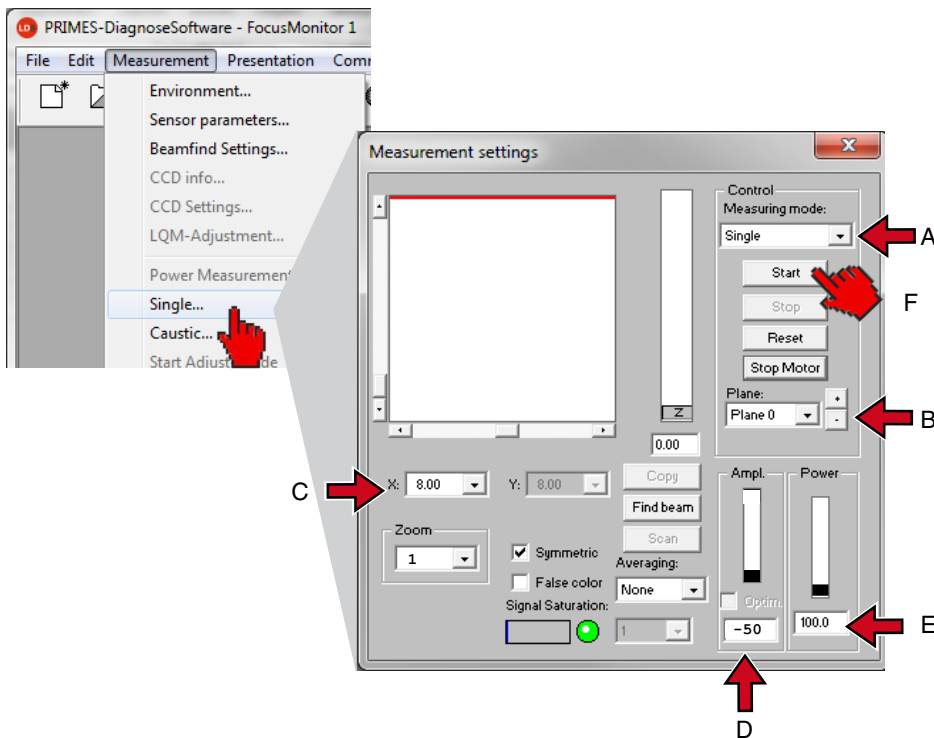

- D In the section **Ampl.** the amplification -50 dB has to be entered.
- E In the section **Power** the laser power has to be entered.
- F Turn on the laser and click on the **Start** button.

If the beam was not found, repeat the measurement with stepwise increased amplification (e.g. 5 dB or 10 dB steps) until the beam is found.

After the detection and the measurement in this plane you can start your caustic measurement.

2. Please open the dialogue window **Measurement** >> **Caustic...** and choose

- A Start plane **Plane 0**.
- B Mode **Automatic**.
- C If active, please deactivate the option **Maximize Window**.
- D Please turn on the laser and click on the **Measurement** button.

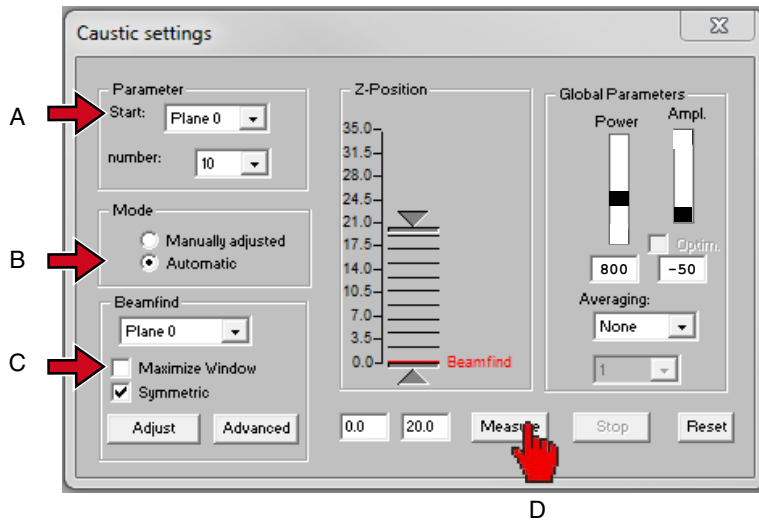

12 Discussion of the Measuring Results and Error Analysis

For the correct interpretation of the measured values as well as the evaluation of the calculated results, the specific characteristics of the FocusMonitor have to be considered.

A comfortable automatic control of the settings and results is offered by the LaserDiagnosticsSoftware with its evaluation function (see Fig. 10.16 on page 53).

By default, the program uses two different methods for the determination of the radius simultaneously (further ones are optionally available).

86%-definition

The beam radius is calculated by means of the beam area into which 86 % of the overall laser power are irradiated. By means of this the radius of a circle can be determined which encloses the same area. This is what the beam radius definition used here is based on (please also see chapter „22 Basis of beam diagnosis“ on page 95).

This definition does only make sense, however, if it a rotation-symmetric laser beam without modulation area (partially low beam intensity) in the beam area is in hand.

2nd Moment Method Definition

The radius of the laser beam is calculated by means of the 2nd moment of the power density distribution of the beam according to ISO 11146 (please also see chapter „22 Basis of beam diagnosis“ on page 95).

Sometimes it is helpful to determine the beam radius manually by means of the 10 – 90 % power density in the **Variable Contour Lines** display. See the optional methods below.

Optional Radius Definitions

- Knife edge method according to ISO 11146
- Slit method according to ISO 11146
- Gauss fit method
- 1/e² power density loss method
- Power inclusion method with freely definable 1st power value
- Power inclusion method with freely definable 2nd power value

Beam Position in the Measuring Window

When positioning the measuring window it has to be ensured that it encloses the complete beam. This is necessary for a correct calculation of the beam radius and the beam position.

Possible maximum window sizes are 8 mm x 8 mm, as an option 16 mm x 8 mm or 24 mm x 12 mm.

Temporal Stability

The FocusMonitor is designed for the measurement of continuous laser beams. Temporal fluctuations of the laser power or changes of the spatial power density distribution might not be measured exactly as soon as the time constant of the fluctuations is smaller than the measuring time of approximately 3 seconds.

Pulsed laser beams can be measured. Interferences between the laser frequency and the scanning frequency of the measuring device can, however, occur. In this case different averaging modes can sometimes help – especially the menu item **Maximum Pixel** as well as **Maximum Trace**.

As an option, a trigger output for pulsed lasers is available for the FocusMonitor. The trigger signal is coupled with the rotation of the measuring tip and can therefore be used for synchronization. The polarity, the pulse width and the delay of the trigger signal are adjustable. The setting possibilities are described in a separate documentation.

In case the power control of the laser is effected via a pulse width modulation (common for high-frequency systems), a modulation of the laser power with the pulse frequency can occur. This leads to a periodic modulation on the measuring result. Possibly, beats may occur.

Transmissive optics (e.g. diffraction plate and lense) typically show a thermal run-in behaviour.

This means that approximately 10 – 20 seconds have to pass after turning on the laser before the optic is thermally balanced. During this time, the calculation index as well as the thickness of the optical material changes which then generally leads to a change of the beam diameter and the beam divergence. This finally results in a change of the focus position. This has to be taken into consideration when evaluating possible measuring results.

If possible, a measurement should only be carried out after an adequate thermalization period. For the measurement of the thermalization of the optics a defined interval between the switch on of the laser and the start-up of the measurement has to be chosen.

For an evaluation of the focus shift the comparison of caustics with a low and a high laser power is often also helpful.

Low Signal-to-Noise Ratio

In case the measured signals only slightly exceed the zero level and the signal-to-noise ratio is low, the calculated beam parameter are displayed in grey instead of black in the overview. In this case it is not sure whether the calculated values for the radius and the position are reliable. Please check the relevance of the measuring values carefully.

Averaging can generally improve the signal-to-noise ratio.

13 Troubleshooting

Error	Possible Reason	Remedy
Error during a measurement	<ul style="list-style-type: none"> Error in the data transmission Processor crash in the measuring system Error in the programme execution 	<ol style="list-style-type: none"> Please restart the system (button Reset in the menu Measurement>>Single Measurement). Turn off the supply voltage and turn it on again and start another reset cycle. Restart the computer.
Beside an ambient noise and the zero offset ¹⁾ no measuring signal is available.	The device is not set up correctly.	Please check the device alignment to the laser beam.
	The power density in the focus is too low.	Please increase the laser power. The absolute power density in the focus typically has to be several hundred kW/cm ² in order to achieve a significant measuring signal with a standard measuring tip.
	For smaller focus spots (e.g. $r_f = 80 \mu\text{m}$) and a maximum measuring window the resolution is too low.	First measure outside the direct focusing range. If no result is achieved, please increase the resolution (e.g. 256 x 256).
	The measuring tip does not work.	The measuring tip has to be replaced (please also see chapter 14.3 on page 83).
	The measuring tip is installed incorrectly.	Twist the measuring tip.
	The signal enhancement is too low.	Please set the maximum enhancement and choose the maximum measuring range in the dialogue window <i>Measurement>>Single...</i> For the presentation please choose the option Autoscale .
The measuring tip is destroyed during the measurement.	The power density is too high so that a plasma is ignited on the surface of the measuring tip.	Please increase the rpm of the measuring tip (please see the tables on page 81 and page 82) and purge the measuring area with helium.
For the measurement of small beams an offset of the measuring track to each other is monitored.	Fluctuations in the synchronism of the rotation disc as well as delays as far as the triggering of the trigger signal is concerned.	The beam position should possible be as close to the left edge of the window as possible. The temporal distance between the trigger signal and the start of the measurement then gets smaller and errors can be reduced. In this case, an averaging is often helpful.

1)) In case of the FocusMonitor typically 150 counts (the current number of "Counts" can be found in the menu item **Presentation>>Variable Contour Lines**).

14 Variety of Detectors and Measurement Tips

There are different measuring tips and detectors available for different wavelengths, power density ranges or beam divergences in order to be able to measure with maximum power. This is how a perfect configuration of the FocusMonitor can be achieved. With regard to the power or the power density only one value can be exploited each.

Measurement tip	High Power CO ₂	High Div YAG	Diode Tip
Typical pin hole diameter in μm	20-25	20	50
Beam divergence/acceptance angle in mrad	< 240	< 200	< 400
Typical wavelength in μm	10-12	0.7-1.1	0.7-1.0
CO₂ Laser			
Max. power density ^{*)} in MW/cm ²	30	—	—
Max. power in kW	15	—	—
Nd:YAG Laser			
Max. power density ^{*)} in MW/cm ²	—	10	1.0
Max. power in kW	—	10	4
Diode Laser			
Max. power density in MW/cm ²	—	2	1
Max. power in kW	—	6	4
Suitable Detectors	DFCM+	DFIG-PS+, DFY-PS+	DFIG-PS+, DFY-PS+

Tab. 14.1: Variety of measuring tips and detectors

*) Please note the damage threshold in Tab. 14.3 on page 81 and Tab. 14.4 on page 82.

The measuring tips are – depending on the model – suitable for different power densities. The power density depends on the laser power and the focus size.

NOTICE

Danger of damage of the measuring tip

In case of very high power densities (CO₂ > 15-20 MW/cm²; YAG > 6 MW/cm²) it may occur that a plasma is ignited on the surface of the measuring tip. This could destroy the measuring tip.

- ▶ **Please increase the rpm according to table Tab. 14.3 on page 81 and Tab. 14.4 on page 82 and – if necessary – purge it with inert gas.**

An integrated protective gas connection is integrated inside the devices with a high power expansion.

In figure Fig. 14.1 a measuring procedure with a destruction of the measuring tip is displayed.

- normal operation

- while a measuring tip was destroyed.

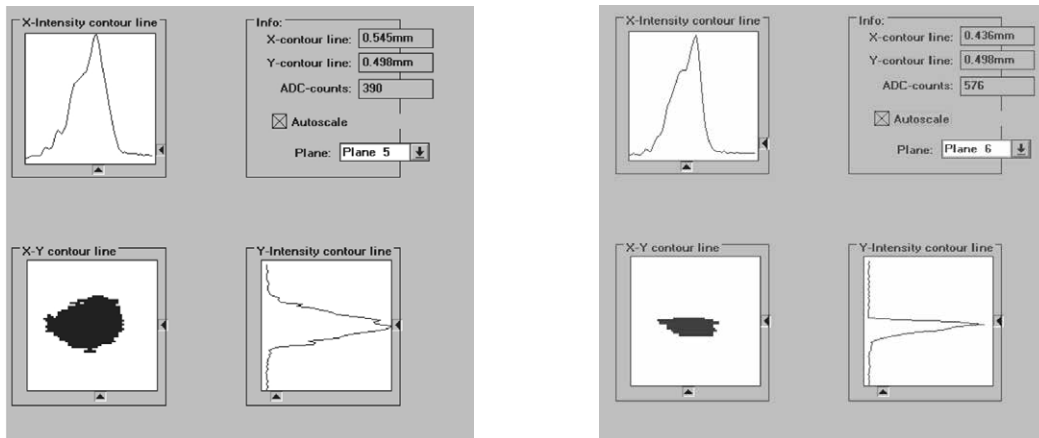

Fig. 14.1: Measuring procedure in the presentation **Variable Contour Lines**

In the right picture it is clearly visible at which point the measurement signal stopped. In case of doubt a measuring tip can be checked for continuity by means of a HeNe laser. Therefore the measuring tip is removed before a 0.5 to 1.0 mW laser shines through the tip from behind. The pinhole should then provide a red reflex.

Please adjust the rotational speed according to the power density which can be found in the tables Tab. 14.3 on page 81 and Tab. 14.4 on page 82. Enter the rpm in the dialogue window **Measurement>>Sensor Parameter**.

Detectors

Depending on the application different detectors are used (please see Tab. 14.1). In order to compensate the varying time performance of the systems, the detectors used are to be selected explicitly in the menu **Measurement>>Sensor Parameter**.

Detector type	Laser	Type of Sensor	Amplification	Wavelength range in µm
DFCM+	CO ₂	Pyro-detector	1	9 – 12
DFY-PS+	NIR/VIS	Photodiode	Automatic adaption of the sensitivity	0.4 – 1.1
DFIG-PS+	NIR	Photodiode	1, 5, 25, 125, (625)	1 – 1.7

Tab. 14.2: Variety of detectors

14.1 Limit Values for the Measurement Procedure with HP-CO₂ Measurement Tips

Specification for a maximum power density is 30 MW/cm² up to 6 kW, between 6 kW and 12 kW up to 20 MW/cm², above up to 20 kW max. 15 MW/cm². The specification is based on a Gauss – profile. The maximum power density in real beams with the same dimensions is often slightly smaller (typically minus 10-20 %, for a Tophat distribution minus 50 %). In case of doubt you should start with a lower laser power

Assignment in the table:

Table element	White	Green	Yellow	Orange	White with red values
Rev. speed in rpm	1875	3750	7500	7500 with inert gas purging	Danger of destruction!

70	5.20	25.98	51.97	77.95	103.94	207.88	311.81	415.75	623.63	1039.38
80	3.98	19.89	39.79	59.68	79.58	159.15	238.73	318.31	477.46	795.77
90	3.14	15.72	31.44	47.16	62.88	125.75	188.63	251.50	377.26	628.76
100	2.55	12.73	25.46	38.20	50.93	101.86	152.79	203.72	305.58	509.30
125	1.63	8.15	16.30	24.45	32.59	65.19	97.78	130.38	195.57	325.95
150	1.13	5.66	11.32	16.98	22.64	45.27	67.91	90.54	135.81	226.35
175	0.83	4.16	8.32	12.47	16.63	33.26	49.89	66.52	99.78	166.30
200	0.64	3.18	6.37	9.55	12.73	25.46	38.20	50.93	76.39	127.32
225	0.50	2.52	5.03	7.55	10.06	20.12	30.18	40.24	60.36	100.60
250	0.41	2.04	4.07	6.11	8.15	16.30	24.45	32.59	48.89	81.49
275	0.34	1.68	3.37	5.05	6.73	13.47	20.20	26.94	40.41	67.34
300	0.28	1.41	2.83	4.24	5.66	11.32	16.98	22.64	33.95	56.59
325	0.24	1.21	2.41	3.62	4.82	9.64	14.47	19.29	28.93	48.22
350	0.21	1.04	2.08	3.12	4.16	8.32	12.47	16.63	24.95	41.58
375	0.18	0.91	1.81	2.72	3.62	7.24	10.86	14.49	21.73	36.22
400	0.16	0.80	1.59	2.39	3.18	6.37	9.55	12.73	19.10	31.83
425	0.14	0.70	1.41	2.11	2.82	5.64	8.46	11.28	16.92	28.20
450	0.13	0.63	1.26	1.89	2.52	5.03	7.55	10.06	15.09	25.15
475	0.11	0.56	1.13	1.69	2.26	4.51	6.77	9.03	13.54	22.57
500	0.10	0.51	1.02	1.53	2.04	4.07	6.11	8.15	12.22	20.37
525	0.09	0.46	0.92	1.39	1.85	3.70	5.54	7.39	11.09	18.48
550	0.08	0.42	0.84	1.26	1.68	3.37	5.05	6.73	10.10	16.84
575	0.08	0.39	0.77	1.16	1.54	3.08	4.62	6.16	9.24	15.40
600	0.07	0.35	0.71	1.06	1.41	2.83	4.24	5.66	8.49	14.15
625	0.07	0.33	0.65	0.98	1.30	2.61	3.91	5.22	7.82	13.04
650	0.06	0.30	0.60	0.90	1.21	2.41	3.62	4.82	7.23	12.05
675	0.06	0.28	0.56	0.84	1.12	2.24	3.35	4.47	6.71	11.18
700	0.05	0.26	0.52	0.78	1.04	2.08	3.12	4.16	6.24	10.39
725	0.05	0.24	0.48	0.73	0.97	1.94	2.91	3.88	5.81	9.69
750	0.05	0.23	0.45	0.68	0.91	1.81	2.72	3.62	5.43	9.05
775	0.04	0.21	0.42	0.64	0.85	1.70	2.54	3.39	5.09	8.48
800	0.04	0.20	0.40	0.60	0.80	1.59	2.39	3.18	4.77	7.96
850	0.04	0.18	0.35	0.53	0.70	1.41	2.11	2.82	4.23	7.05
900	0.03	0.16	0.31	0.47	0.63	1.26	1.89	2.52	3.77	6.29
950	0.03	0.14	0.28	0.42	0.56	1.13	1.69	2.26	3.39	5.64
1000	0.03	0.13	0.25	0.38	0.51	1.02	1.53	2.04	3.06	5.09
1500	0.01	0.06	0.11	0.17	0.23	0.45	0.68	0.91	1.36	2.26
2000	0.01	0.03	0.06	0.10	0.13	0.25	0.38	0.51	0.76	1.27
	0.10	0.50	1.00	1.50	2.00	4.00	6.00	8.00	12.00	20.00

Tab. 14.3: Power density in MW/cm²

The durability of the measuring tip not only depends on the power density but also on the purity of the surface (dust, particles, fingerprints). Please handle the measuring tip with the utmost care.

14.2 Limit Values for the Measurement Procedure with FK High Div-Measurement Tips

The specification is based on a Tophat Profile. The maximum power density in real beams with the same dimensions is often higher (typically plus 10 % - 60 %, for a Gauss – distribution plus 100 %). In case of doubt you should start with a low laser power. The maximum power density is up to 5 kW of power 10 MW/cm². In case of higher powers we only have little experience. We recommend not to work with more than 8 MW/cm² (up to 12 kW), or – respectively, max. 6 MW/cm² up to 20 kW.

Assignment in the table:

Table element	White	Green	Yellow	Orange	White with red values
Rev. speed in rpm	1875	3750	7500	7500 with inert gas purging	Danger of destruction!

70	2.60	12.99	25.98	38.98	51.97	103.94	155.91	207.88	311.81	519.69
80	1.99	9.95	19.89	29.84	39.79	79.58	119.37	159.15	238.73	397.89
90	1.57	7.86	15.72	23.58	31.44	62.88	94.31	125.75	188.63	314.38
100	1.27	6.37	12.73	19.10	25.46	50.93	76.39	101.86	152.79	254.65
125	0.81	4.07	8.15	12.22	16.30	32.59	48.89	65.19	97.78	162.97
150	0.57	2.83	5.66	8.49	11.32	22.64	33.95	45.27	67.91	113.18
175	0.42	2.08	4.16	6.24	8.32	16.63	24.95	33.26	49.89	83.15
200	0.32	1.59	3.18	4.77	6.37	12.73	19.10	25.46	38.20	63.66
225	0.25	1.26	2.52	3.77	5.03	10.06	15.09	20.12	30.18	50.30
250	0.20	1.02	2.04	3.06	4.07	8.15	12.22	16.30	24.45	40.74
275	0.17	0.84	1.68	2.53	3.37	6.73	10.10	13.47	20.20	33.67
300	0.14	0.71	1.41	2.12	2.83	5.66	8.49	11.32	16.98	28.29
325	0.12	0.60	1.21	1.81	2.41	4.82	7.23	9.64	14.47	24.11
350	0.10	0.52	1.04	1.56	2.08	4.16	6.24	8.32	12.47	20.79
375	0.09	0.45	0.91	1.36	1.81	3.62	5.43	7.24	10.86	18.11
400	0.08	0.40	0.80	1.19	1.59	3.18	4.77	6.37	9.55	15.92
425	0.070	0.35	0.70	1.06	1.41	2.82	4.23	5.64	8.46	14.10
450	0.063	0.31	0.63	0.94	1.26	2.52	3.77	5.03	7.55	12.58
475	0.056	0.28	0.56	0.85	1.13	2.26	3.39	4.51	6.77	11.29
500	0.051	0.25	0.51	0.76	1.02	2.04	3.06	4.07	6.11	10.19
525	0.046	0.23	0.46	0.69	0.92	1.85	2.77	3.70	5.54	9.24
550	0.042	0.21	0.42	0.63	0.84	1.68	2.53	3.37	5.05	8.42
575	0.039	0.19	0.39	0.58	0.77	1.54	2.31	3.08	4.62	7.70
600	0.035	0.18	0.35	0.53	0.71	1.41	2.12	2.83	4.24	7.07
625	0.033	0.16	0.33	0.49	0.65	1.30	1.96	2.61	3.91	6.52
650	0.030	0.15	0.30	0.45	0.60	1.21	1.81	2.41	3.62	6.03
675	0.028	0.14	0.28	0.42	0.56	1.12	1.68	2.24	3.35	5.59
700	0.026	0.13	0.26	0.39	0.52	1.04	1.56	2.08	3.12	5.20
725	0.024	0.12	0.24	0.36	0.48	0.97	1.45	1.94	2.91	4.84
750	0.023	0.11	0.23	0.34	0.45	0.91	1.36	1.81	2.72	4.53
775	0.021	0.11	0.21	0.32	0.42	0.85	1.27	1.70	2.54	4.24
800	0.020	0.10	0.20	0.30	0.40	0.80	1.19	1.59	2.39	3.98
850	0.018	0.09	0.18	0.26	0.35	0.70	1.06	1.41	2.11	3.52
900	0.016	0.08	0.16	0.24	0.31	0.63	0.94	1.26	1.89	3.14
950	0.014	0.07	0.14	0.21	0.28	0.56	0.85	1.13	1.69	2.82
1000	0.013	0.06	0.13	0.19	0.25	0.51	0.76	1.02	1.53	2.55
1500	0.006	0.03	0.06	0.08	0.11	0.23	0.34	0.45	0.68	1.13
2000	0.003	0.02	0.03	0.05	0.06	0.13	0.19	0.25	0.38	0.64
3000	0.001	0.01	0.01	0.02	0.03	0.06	0.08	0.11	0.17	0.28
	0.10	0.50	1.00	1.50	2.00	4.00	6.00	8.00	12.00	20.00

Tab. 14.4: Power density in MW/cm²

The durability of the measuring tip not only depends on the power density but also on the purity of the surface (dust, particles, fingerprints). Please handle the measuring tips with the utmost care.

14.3 Exchanging or Twisting the Measurement Tip

NOTICE

Danger of damage of the measuring tip

The very small pinhole at the top of the measuring tip could be blocked quickly by dirt particles or when touched with bare hands.

- ▶ Please wear powder-free latex gloves during the mounting/dismounting and please ensure a dirt- and dust free environment.

Assembly order:

1. Please turn off the supply voltage.
2. Please turn the FM+ upside down.
3. Please turn the rotational disk until the measuring tip in the housing recess becomes visible.
4. Please remove the fastening screws of the retaining plate (previous hexagon socket a. f. 1.5 mm, current Torx T8).

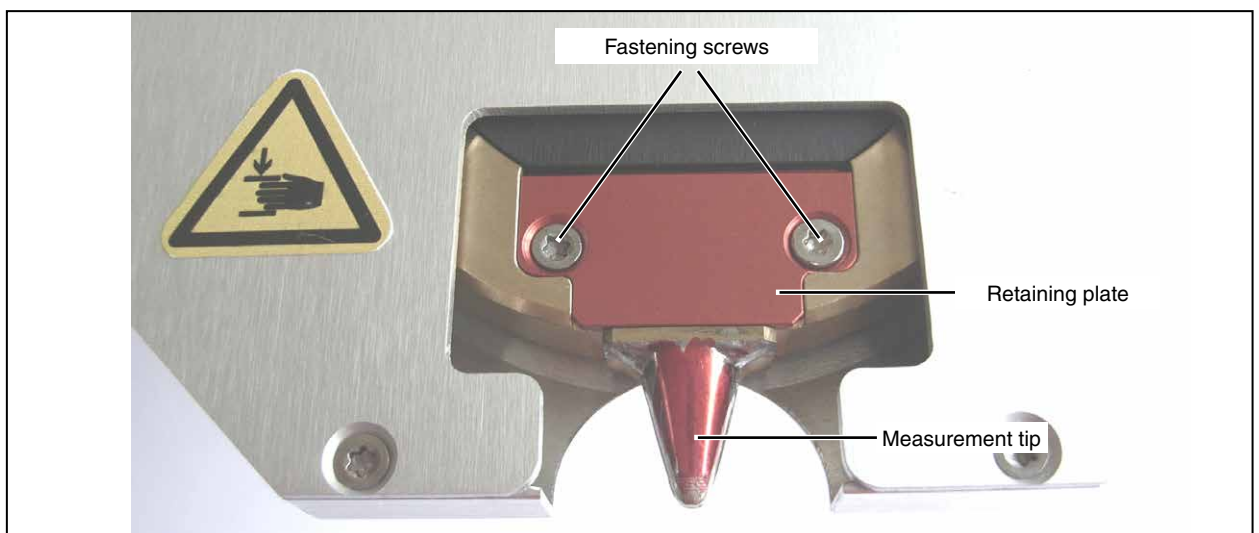

Fig. 14.2: Measurement tip, view from below

5. The measuring tip and the retaining plate have to be pushed out of the rotational disc carefully through the housing bore. This must be effected from below and by means of a screwdriver. (please see Fig. 14.3).

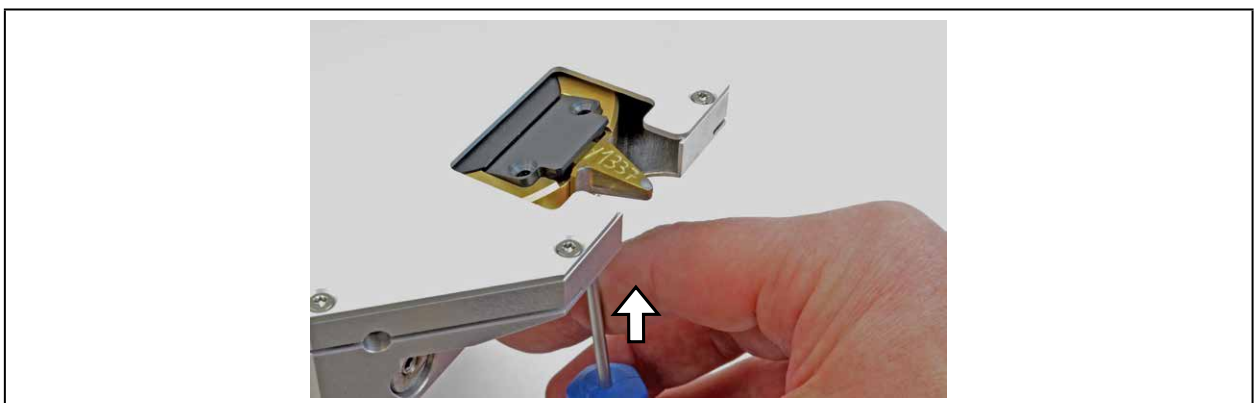

Fig. 14.3: Pushing out the measuring tip

6. Slightly pull the retaining plate up and forward until it loosens and can be removed.
7. Carefully remove the measuring tip.
8. Put in the new measuring tip (please note that the pinhole is located on the convex side, please see Fig. 14.4), or turn the measuring tip.

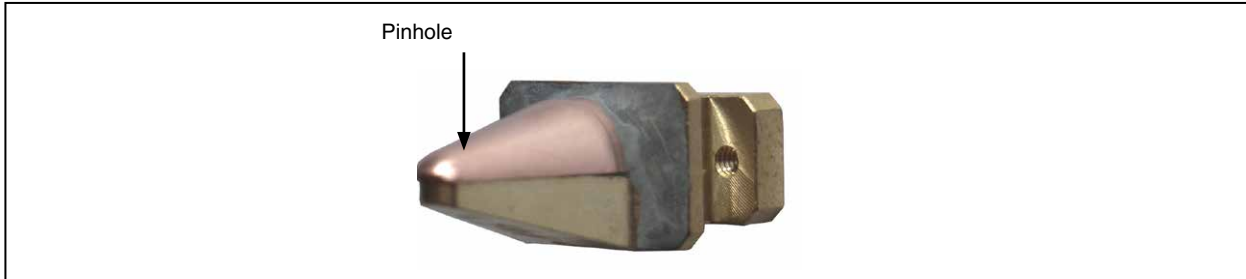

Fig. 14.4: Opening aperture (pin hole) in the measuring tip

9. Put the retaining plate into the rotational disc with an angle of about 45 degrees, ensuring that the guide groove is pointing upwards. Then it has to be pushed down into the recess (please see Fig. 14.5).
10. Check whether the retaining plate is positioned correctly by lightly pressing the leading edge.

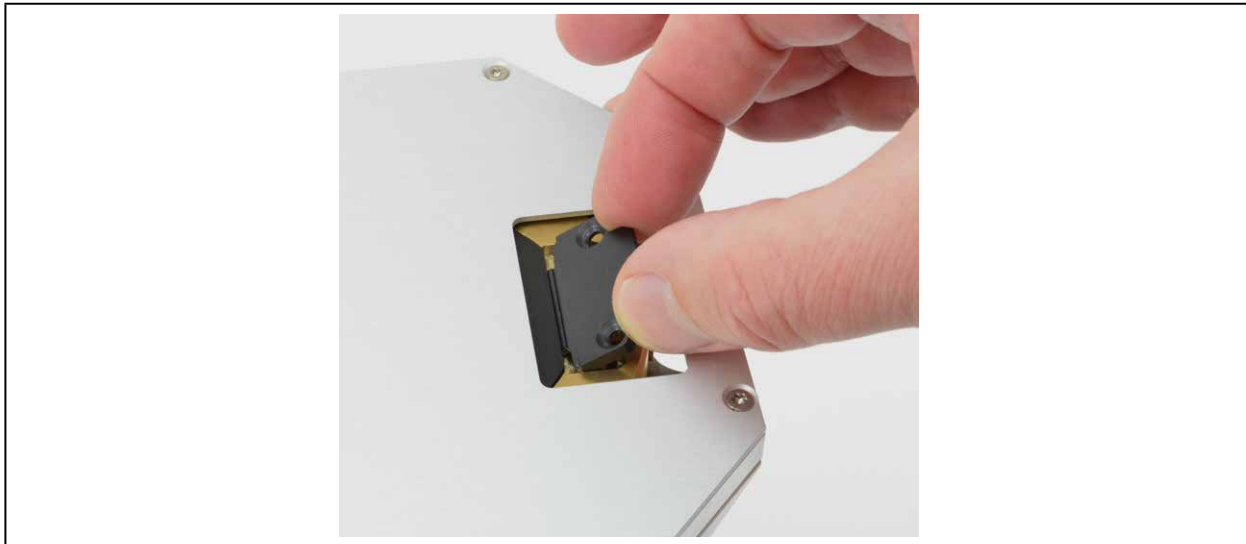

Fig. 14.5: Putting in the retaining plate

11. Put in the screws and tighten it manually.



In case you have turned the measuring tip, you should activate the option “Twisted Tip” in the software (please see page 38) in order to ensure the correct orientation of the x-coordinate.)

14.4 Changing the Detector

In general, the FocusMonitor is equipped with a DFIG-PS+ or a DFCM+ detector. For special applications, this detector can be replaced by a system with a changed sensitivity or a different time response. More information regarding the variety of detectors for an optimal configuration of the FocusMonitor can be found in the table Tab. 14.1 on page 79).

NOTICE

Danger of damage for the detector sensor

The detector sensor must not be damaged and has to be protected from contaminations of any kind.

- ▶ Do not touch the detector sensor with your fingers and do not put it down on the sensor surface.

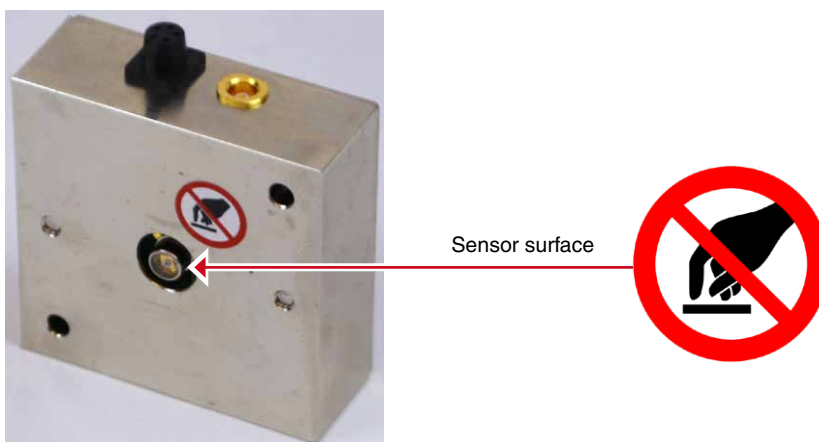

Please only use isolating plastic screws in order to fasten the detector in order to prevent noise signals. Do not forget the foam rubber plate during the installation. Otherwise the rotational disc could be mechanically blocked by the screws. The foam rubber plate also ensures a mechanical decoupling and electrical isolation of the detector.

Assembly Order:

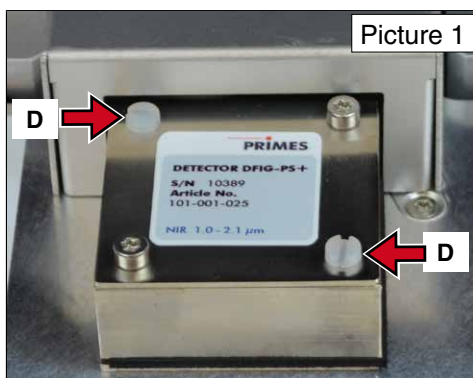

1. Please turn off the voltage supply.
2. Remove the plastic screws (D) on the detector (picture 1).

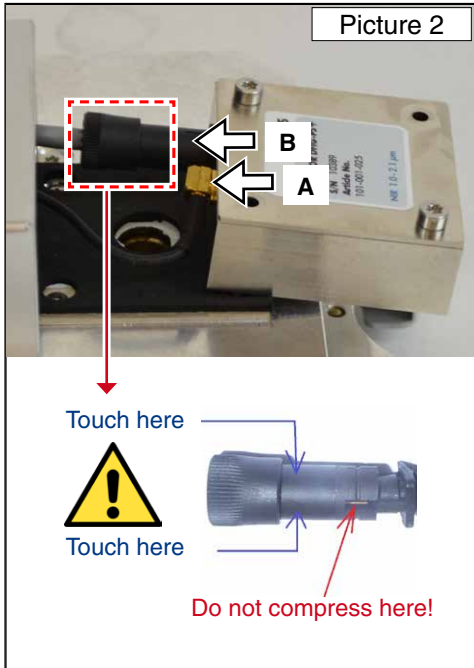

3. Take the detector carefully out of the position and first loosen the golden angle plug (A), then the black plug (B) on the backside of the detector.
Please do not pull the cables!

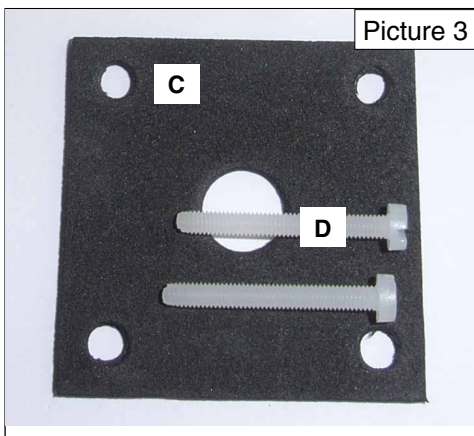

4. For the installation of the new detector, please first place the foam rubber plate (C) on the mounting surface of the detector (picture 3). Then the cables are connected. When placing the detector, please make sure that it has a distance to the housing on both sides (picture 4).
5. Please fasten the detector with the two plastic screws (D).

 If the screws are tightened too firmly, they might block the rotary disc! Only tighten the screws **hand-tight**.

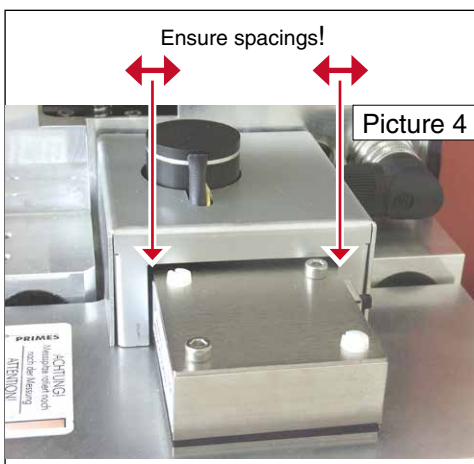

When changing the sensitivity of the detector, please restart the device by turning the voltage supply back on and by clicking on **Reset**.

15 Maintenance

Under ordinary operation conditions both the FocusMonitor work mostly without maintenance. In a very dusty environment we recommend the careful cleaning of the guides as well as of the spindles by means of Isopropanol. Moreover, they also should be greased slightly. In general we recommend a regular service carried out by the manufacturer every 12 – 24 months.

16 Transport

To prevent damages, we recommend transporting the FM+ either in its original packaging or in a PRIMES transport box. In case of unpredictable transport conditions, please remove the measuring tip of the FocusMonitor and put it in the enclosed plastic case.

17 Measures for the product disposal

Due to the Electrical and Electronic Equipment Act (Elektro-G) PRIMES is obliged to dispose PRIMES measuring devices manufactured after August 2005 free of charge. PRIMES is registered in the German "Used Appliance Register " (Elektro-Altgeraete-Register EAR) as a manufacturer with the number WEEE-Reg.-Nr. DE65549202.

Within the EU you are welcome to send your PRIMES devices to the following address, in case you want them to be disposed:

PRIMES GmbH
Max-Planck-Str. 2
D-64319 Pfungstadt
Germany

18 Declaration of Conformity**Original EG Declaration of Conformity**

The manufacturer: PRIMES GmbH, Max-Planck-Straße 2, 64319 Pfungstadt, Germany,
hereby declares that the device with the designation:

FocusMonitor (FM)

Types: FM35; FM120; FM+ 120; FMW; FMW+

is in conformity with the following relevant EC Directives:

- Machinery Directive 2006/42/EC
- EMC Directive EMC 2014/30/EU
- Low voltage Directive 2014/35/EU
- Directive 2011/65/EC on the restriction of the use of certain hazardous substances (RoHS) in electrical and electronic equipment
- Directive 2004/22/EC on measuring instruments

Authorized for the documentation:

PRIMES GmbH, Max-Planck-Straße 2, 64319 Pfungstadt, Germany

The manufacturer obligates himself to provide the national authority in charge with technical documents in response to a duly substantiated request within an adequate period of time.

Pfungstadt, April 26, 2017



Dr. Reinhard Kramer, CEO

19 Technical Data

Supply data		
Supply voltage, DC	V	24 ± 10 %
Maximum current consumption	A	4
Max. current consumption in standby mode	A	0.4
Protective gas (water and oil free) Maximum pressure	bar	He or N ₂ or Ar 0.5
Characteristics measurement		
Max. power density range (details on page page 81 and pagepage 82)		
CO ₂ -Laser	MW/cm ²	30
HighDivYAG	MW/cm ²	10
Diode	MW/cm ²	1
Beam diameter, typ.	µm	150 ... 3,000
Weights and measures		
Dimensions, L x W x H	mm	280 x 242 x 218
Weight, approx.	kg	8.5
Ambient Conditions		
Operating Temperature Range	°C	+10 ... +40
Storage Temperature Range	°C	+5 ... +50
Reference Temperature	°C	+22
Admissible Relative Air Humidity (non-con- densing)	%	10 ... 80

20 Dimensions

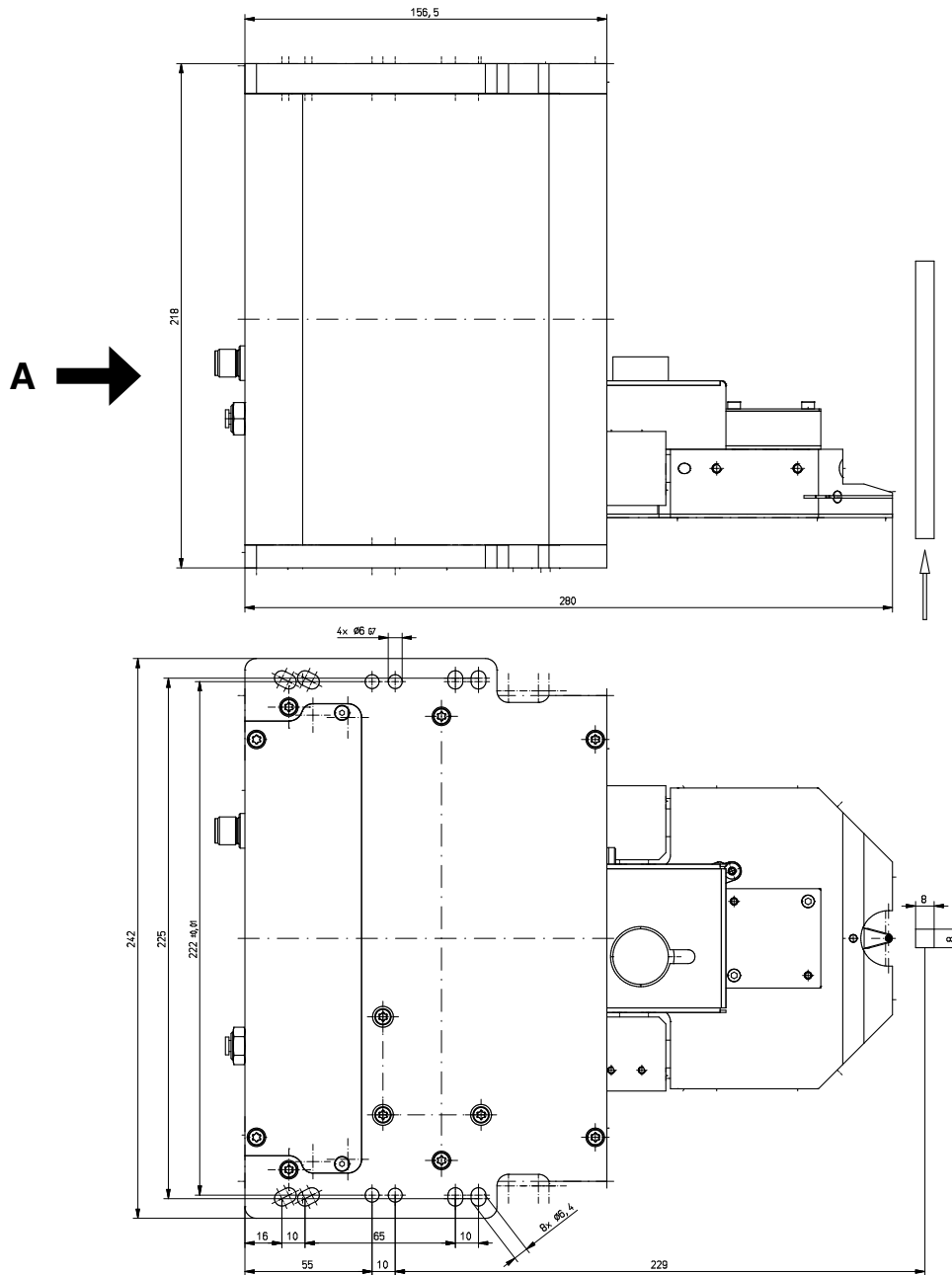

All dimensions in mm (general tolerance ISO 2768-v)

View A

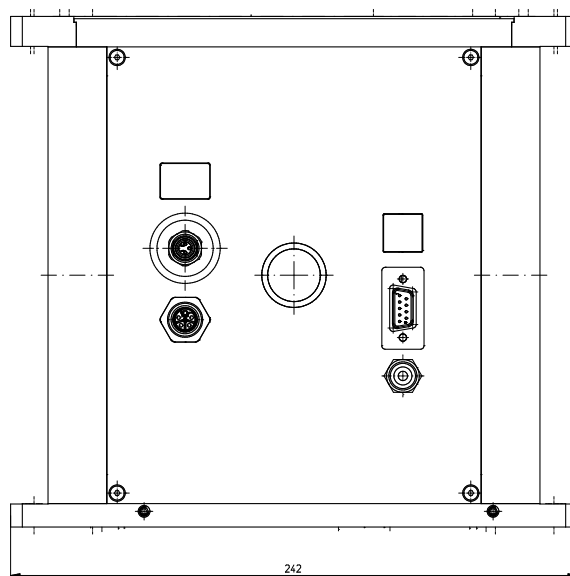

All dimensions in mm (general tolerance ISO 2768-v)

20.1 Position of the Pinhole Tip at the FocusMonitor (in reference to the device coordinates)

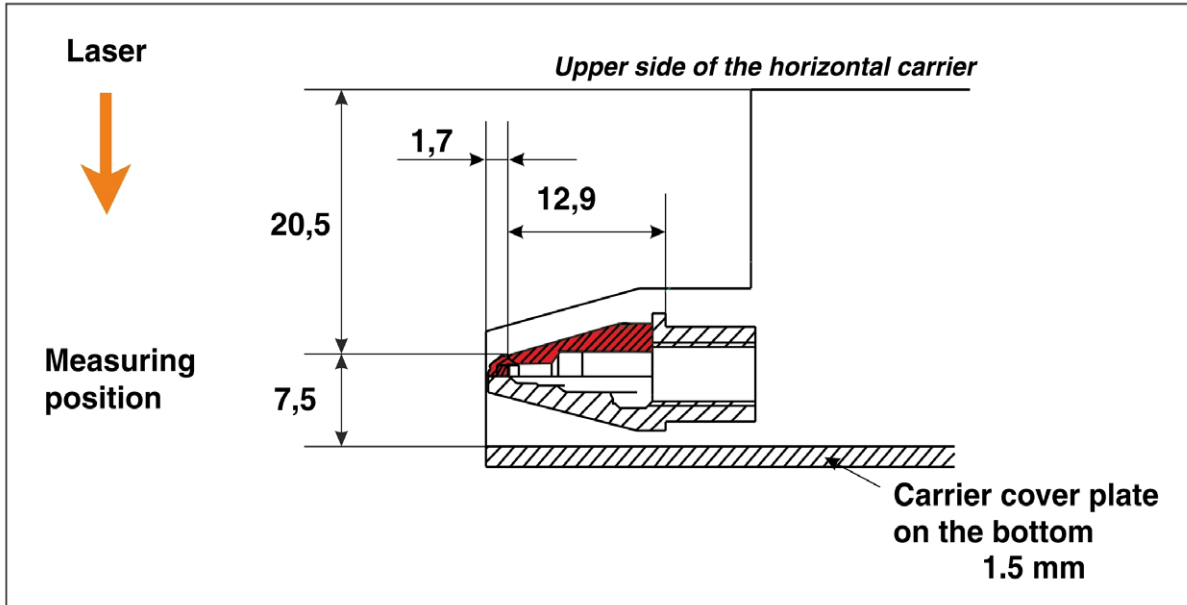

Fig. 20.1: Upper measurement aperture

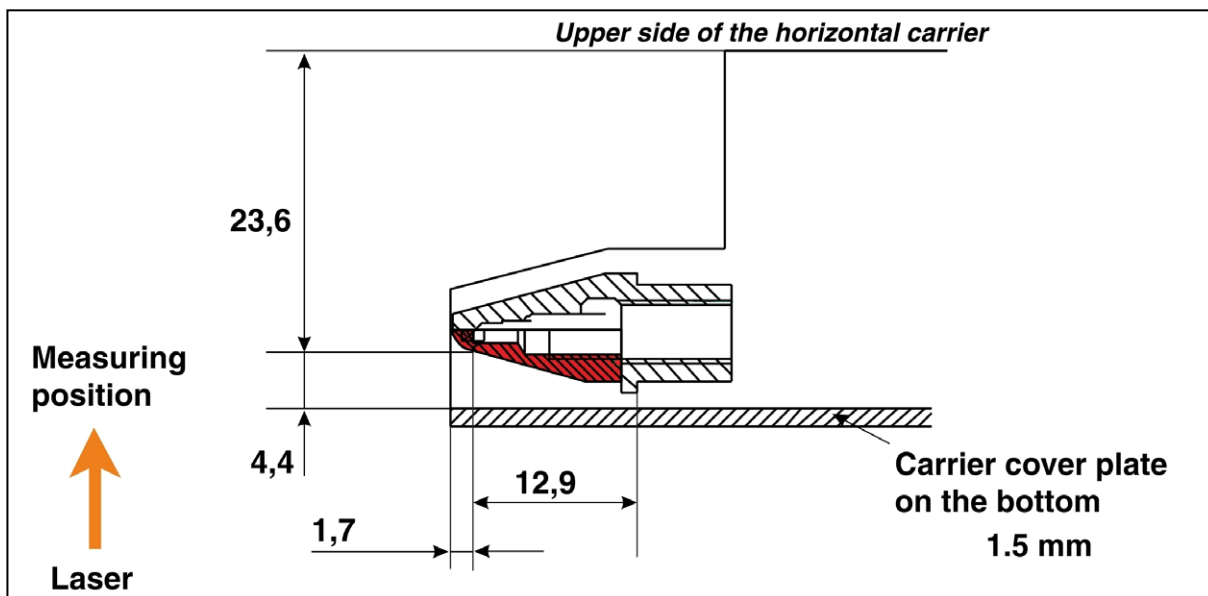

Fig. 20.2: Bottom measurement aperture (turned measuring tip)

All dimensions in mm (general tolerance ISO 2768-v)

21 Appendix

21.1 System control

With a PLC interface a communication of the measuring device and the PLC control of the laser is possible. It is, for example, possible to send warning messages or correction signals to the laser-/system control, in case the focus position or focus radius change significantly.

A second possibility would be to start measurements from the processing system automatically. The variation of system- or laser parameters for different measurements can also be automated e.g. the focus measurement for different output powers of the laser.

PRIMES offers a PLC interface with 16 input- and 16 output channels. For the inputs CNY 17 compatible opto-couplers for a potential-free connection are used.

The **BeamControlSystem** (BCS) by PRIMES includes the FocusMonitor as a component for the power density- and caustic measurement and offers a PROFIBUS interface for the system communication.

21.2 Description of the MDF file format

The MDF file format is a simple ASCII-format which includes the main data of a beam measurement – the spatial power density distribution. MDF stands for “Measurement Data Format”.

By means of this standardized format conversion problems between different evaluation programs are supposed to be reduced and a safe data transmission, e.g. per e-mail, is supposed to be ensured.

An important factor contributing to the success of MDF is its ability to store measurement data very efficiently, i.e., memory space-saving and fast storage. Moreover, the read access to data in the file can also be optimized. To do so, the file must, if necessary, be “sorted” once (for example, when opening it for the first time). This enables indexed and thus faster access to the data.

MDF contains both the raw measurement data acquired during a measurement and metadata necessary for interpreting the raw data. This includes, for example, information for converting the raw data into physical values, or the ASAM-compliant signal name.

The files are arranged as follows:

Line	Contents
1	MDF100 (file identifier)
2	Number of image points: in x-direction in y-direction
3	Size of the measurement range: length in x (mm) length in y (mm)
4	Position along the beam axis: z-position (mm)
5	Transversal position of the center of the measurement range: x-pos y-pos (mm)
6	Amplification of the measuring signal: enhancement (dB)
7	Number of averages: number
8	Offset value displayed by the measuring device: offset-value
9	Wavelength-value
10	Power value
11	Focal length value
12	Date, time value
x	In the following lines the data can be found. There is a maximum of 80 characters per line.
x	
x	

Comments

Comments are inserted as additional lines, into the lines after the file identifier.
The comment lines each start with a semi-colon.

Example:

```
MDF100
;This is an example.
;These lines are a comment.
64 64
2 2
11
...
...
1
10
10 10 10 10 10 10 10 10 10 10
11 12 13 14 15 16 17 18 19 20
20 20 20 20 20 18 16 14 12 10
....
....
```

22 Basis of beam diagnosis

22.1 Laser beam parameter

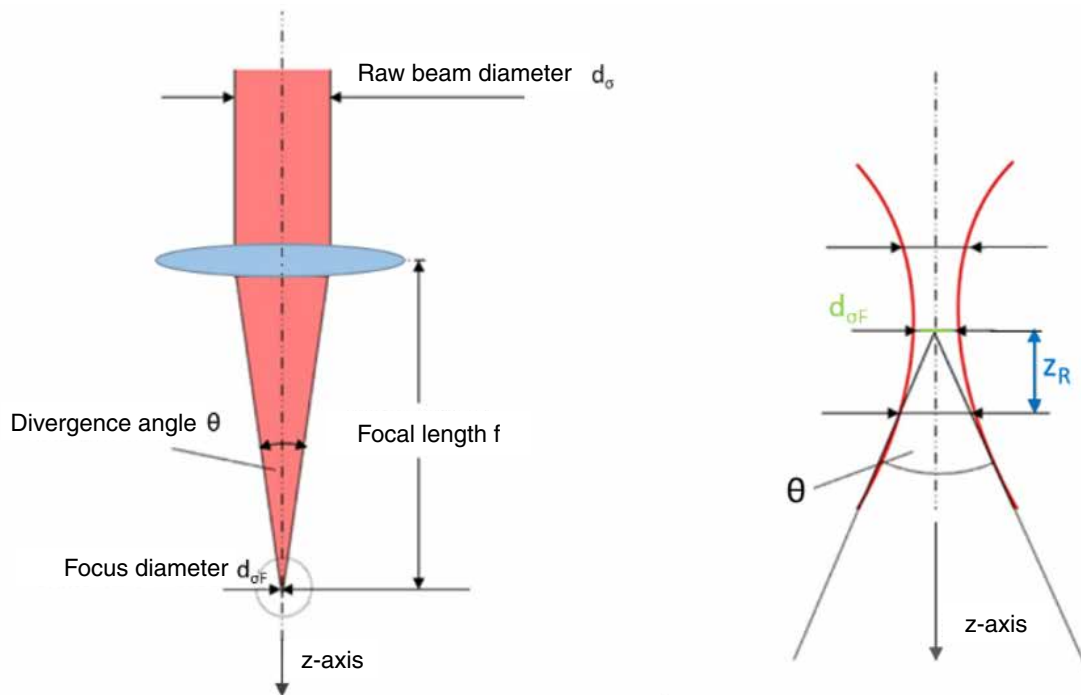

Fig. 22.1: Sketch for the definition of beam parameters

22.1.1 Rotationally symmetric beams

According to ISO 11145 as well as ISO 11146 three beam parameters are necessary for the characterization of a rotationally symmetric beam:

- the z-position of the beam waist (focus) z_0
- the diameter of the beam waist $d_{\sigma F}$
- the far field divergence angle Θ

By means of these three values it is possible to determine the beam diameter at every spot along the propagation direction. The following restriction is applicable: The divergence angle has to be smaller than 0.8 rad and the focus diameter and the divergence angle were determined with the 2nd moment method.

Equation 1:
$$d_{\sigma}(z) = \sqrt{d_{\sigma 0}^2 + \frac{1}{4}(z - z_0)^2 \cdot \theta_{\sigma}^2}$$

Furthermore, the beam propagation is described by means of the so called beam propagation ratio K.

Equation 2:
$$K = \frac{1}{M^2} = \frac{4 \cdot \lambda}{\pi} \cdot \frac{1}{d_{\sigma 0} \cdot \theta_{\sigma}}$$

with:

- K: = beam propagation ratio
- M^2 : = beam quality factor
- λ : = wave length in a medium with the refractive index n
- Θ_{σ} : = divergence angle
- $d_{\sigma 0}$: = beam waist diameter

The derived beam parameter product, is a constant size as long as image defect free and aperture free components are used.

Equation 3:
$$BPP = \frac{d_{\sigma 0} \cdot \theta}{4} = \frac{\lambda}{\pi \cdot k} = \frac{M^2 \cdot \lambda}{\pi}$$

An important beam parameter is the Rayleigh length:

The Rayleigh length is the distance towards the propagation in which the laser beam has increased by $\sqrt{2}$. It can be calculated by means of the following formula:

Equation 4:
$$z_R = \frac{d_{\sigma 0}}{\theta} = \frac{\pi \cdot d_{\sigma 0}^2}{4\lambda \cdot M^2}$$

22.1.2 Non rotationally symmetric beams:

In order to describe non rotationally symmetric beams, the following parameters are required:

- the z-position of the beam waist (focus) z_x and z_y
- the diameter of the beam waist $d_{\sigma 0x}$ and $d_{\sigma 0y}$
- the far field divergence angle $\Theta_{\sigma x}$ and $\Theta_{\sigma y}$
- the angle φ between the x' -axis of the measuring system and the x-axis of the beam (the x-axis of the beam is the one closest to the x-axis of the measuring system.)

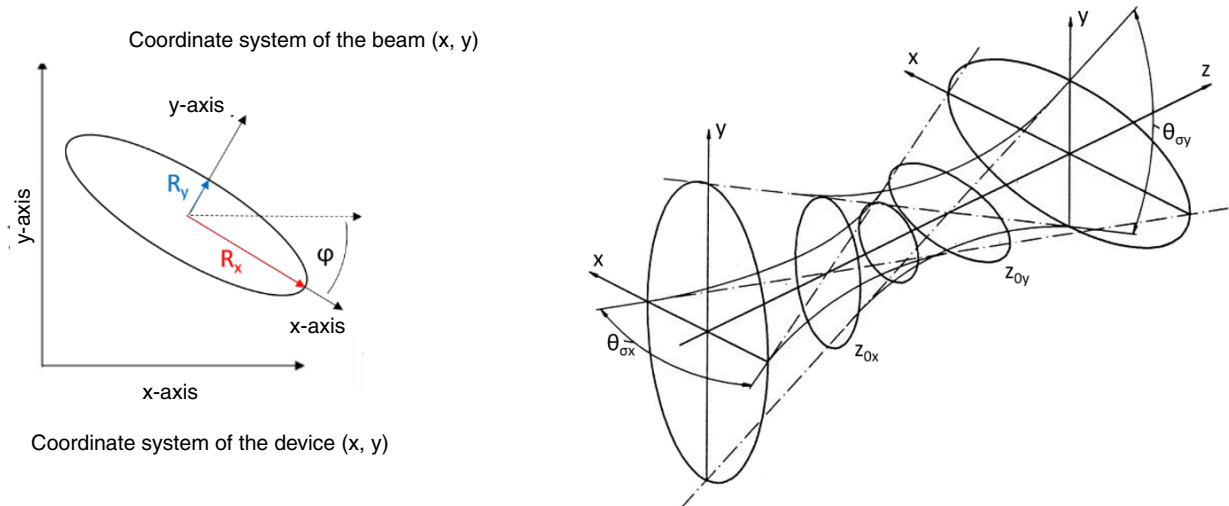

Fig. 22.2: Beam parameter of the not rotationally symmetric beam

All beams which can be characterized by two axes which are perpendicular to each other can be described by means of the above mentioned parameters.

Further beam parameter such as the K-figure or the beam quality factor are calculated directionally by means of as the same equations as the rotationally symmetric beams. This always results in two parameters such as K_x and K_y .

22.2 Calculation of beam data

For the calculation of the beam data not only the algorithms for the 2nd moment method are implemented as demanded by the ISO standard 11145 but also the 86 % method which is widely-spread within the industry. For the Gaussian TEM00-mode both methods offer similar results whereas in case of the majority of other laser beams the 2nd moment method calculates bigger beam diameters than the 86 % method.

Laser radiation often is a mixture of different modes with different frequencies and coherent characteristics. All known measuring procedures only provide little information on the beam. Therefore the calculated beam parameters are always dependent on the measuring procedure. For the interpretation of the measuring results it is important to be aware of this fact.

The calculation of the beam radius requires the following to preparatory steps.

1. Measurement of the power density distribution
2. Determination of the zero level
3. Determination of the beam position

22.2.1 Determination of the zero level

The zero level can – for instance – be determined by means of a histogram by applying the frequency of the measured power density values (please see Fig. 22.3).

• **Zero level of the signal**

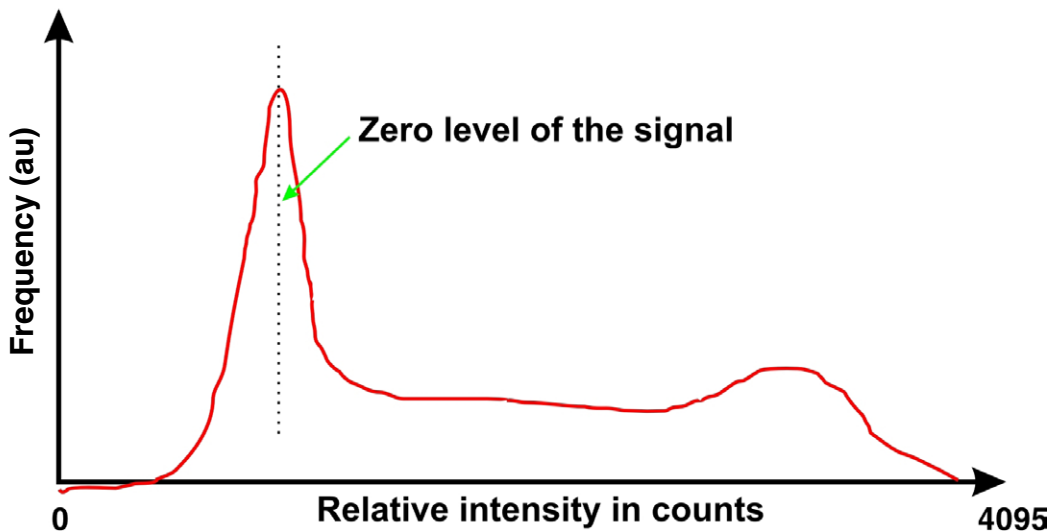

Fig. 22.3: Schematic histogram of the scanned measuring points

The histogram shows how frequently a certain power density was measured. The maximum of this curve indicates the power density of the zero level. The power density is deducted from all measured values of the power density distribution.

It is important to measure the zero level accurately because even the slightest error would lead to a drastic change as far as the volume is concerned. This in turn has a great impact on the measured beam radius.

22.2.2 Determination of the beam position

The beam position is determined by means of the 1st moment method. This means the moment of inertia of the power density distribution ($E(x, y, z)$) is determined.

$$\text{Equation 5: } \quad \bar{x} = \frac{\iint x \cdot E(x, y, z) dx dy}{\iint E(x, y, z) dx dy} \quad \bar{y} = \frac{\iint y \cdot E(x, y, z) dx dy}{\iint E(x, y, z) dx dy}$$

As mentioned at the beginning of the chapter, there are two possibilities how to determine the beam radius after the determination of the beam position.

22.2.3 Radius determination with the 2nd moment method of the power density distribution

The calculation of the beam radius according to the 2nd moment method of the power density distribution is effected as shown in equation 6.

Equation 6:

$$\sigma_x^2(z) = \frac{\iint (x - \bar{x})^2 \cdot E(x, y, z) dx dy}{\iint E(x, y, z) dx dy} \quad \sigma_y^2(z) = \frac{\iint (y - \bar{y})^2 \cdot E(x, y, z) dx dy}{\iint E(x, y, z) dx dy}$$

Based on equation 6 the beam diameter is determined as follows:

$$d_{\sigma_x}(z) = 4 \cdot \sigma_x(z)$$

Equation 7:

$$d_{\sigma_y}(z) = 4 \cdot \sigma_y(z)$$

This algorithm contains the product derived from the power density and the squared distance to the moment of inertia. It is only reliable when the zero level is determined correctly. The fill factor, the ratio of the beam diameter divided by the integration range/measuring window size is a further important quantity. It should always have a value between 0.3 and 0.6.

22.2.4 Radius determination with the method of the 86 % power inclusion

The first step is the determination of the volume of the power density distribution. It is proportional to the total power. The addition of all power density values and their multiplication with the pixel dimensions result in the volume and therefore the total power. A reliable zero level subtraction is the fundamental basis.

Based on this total power, the focus lies on the range which includes the 86 % of the total beam power. This beam power must lie within the beam radius.

The integration typically starts with the values of the maximum power density. Then the integration range is enlarged until 86 % of the total power lie within the radius. As far as the integration is concerned, the number of pixels is counted. By means of this the 86 % range which means the beam diameter can be determined. For circular beams similar to the fundamental mode beams the procedure works well.

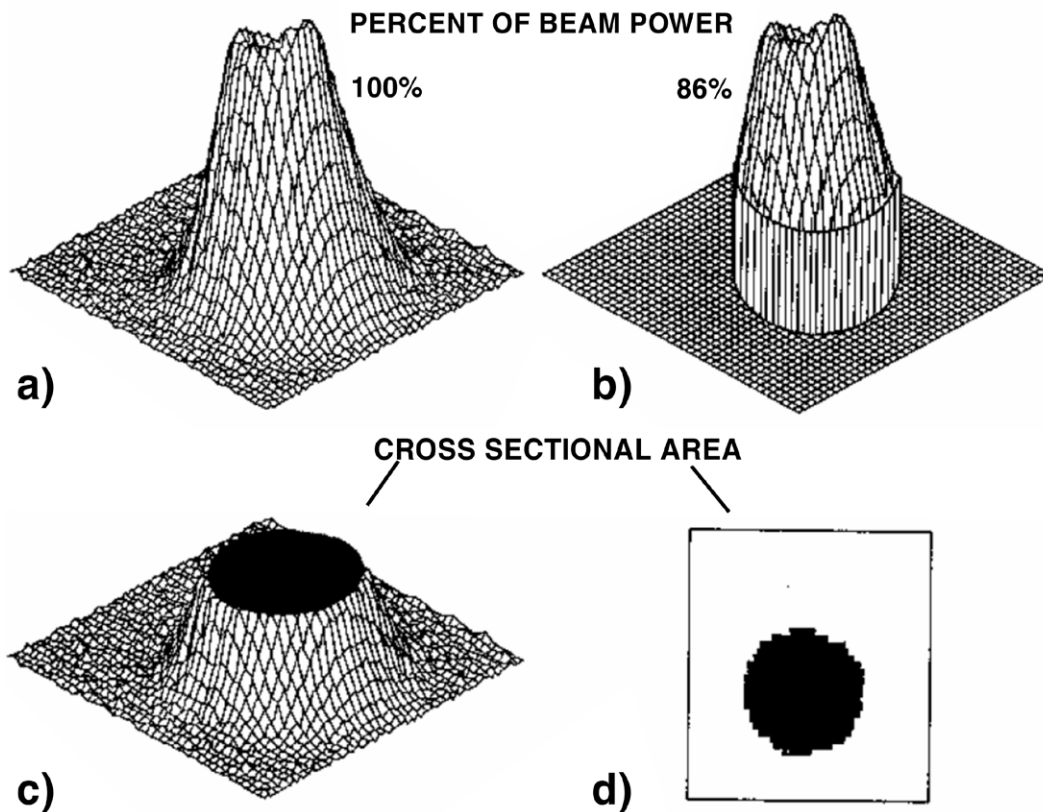

Fig. 22.4: Graphical presentation of the calculation of the 86% radius

- a) shows the power density distribution
- b) shows the pixels which include 86 % of the power together. As a clarification the pixels with a low power are set to zero.
- c) shows a section at the “86 % power density inclusion”. The level lies at 14 % of the maximum power
- d) shows the section through the distribution at 86 %.

22.2.5 Further radius definitions **OPTION******

Not all measuring devices for the laser beam diagnosis come to the same measuring result when carrying out similar measurements with the same laser beam. Apart from a different validation of the measuring devices the measuring procedures and the used evaluation algorithms have an influence on the determined beam dimension. Not all the processes used comply with the valid standards. However, they are the preferred choice for instance in the scientific area. For practical reasons, for instance for the design of the orifices or for the correlation with processing results, it can also be helpful to use alternative beam radius definitions.

As an option, we offer an extension to the following alternative radius definitions:

1. Knife edge method according to ISO 11146-3
2. Slit method according to ISO 11146-3
3. Gaussfit method
4. 1/e² power density loss method
5. Power inclusion method with a freely definable 1st power value
6. Power inclusion method with a freely definable 2nd power value

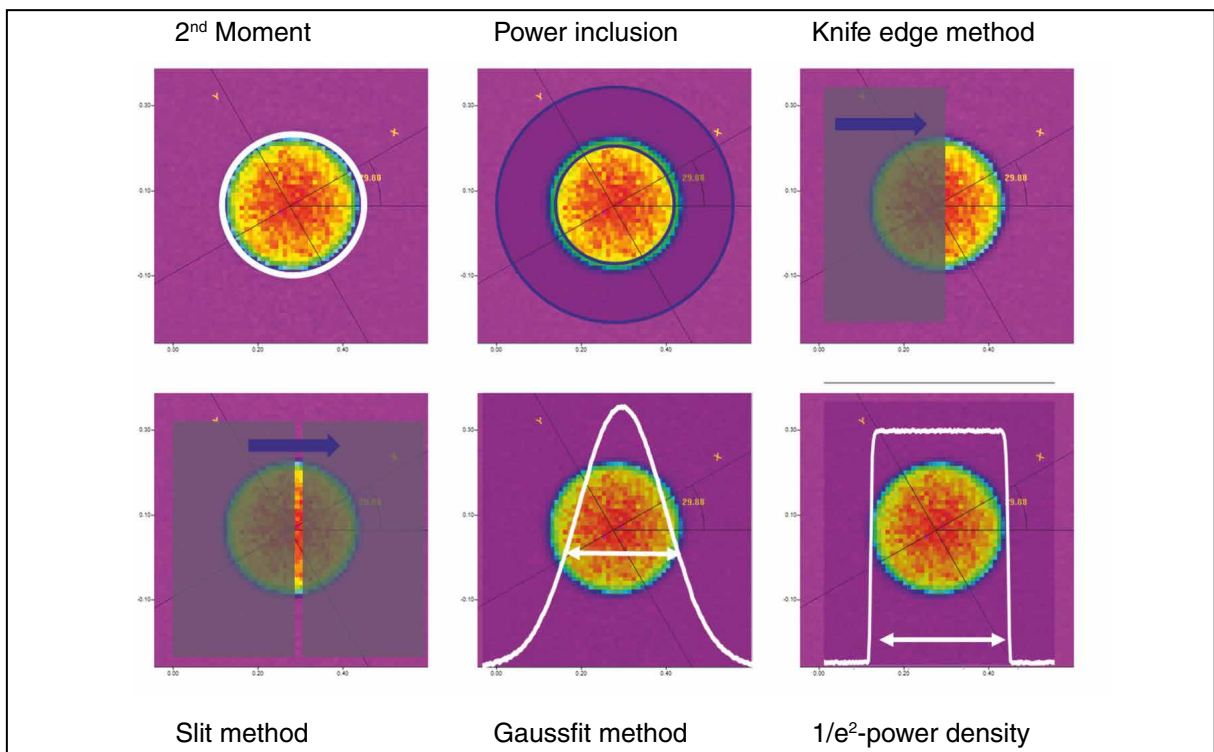

Fig. 22.5: Schematic illustration of the beam radius definitions that are offered optionally for the PRIMES LaserDiagnosticsSoftware

